

# Rotary and Handling Tools Catalog

2013 Land and Offshore



# GENERAL INFORMATION

This catalog is intended to provide general information. Every effort has been made to ensure the accuracy of the information contained herein. National Oilwell Varco, L.P. and its associated and affiliated companies (hereinafter collectively referred to as "NOV") will not be held liable for errors in this material, or for consequences arising from misuse of this material.

## GENERAL INFORMATION

### About this issue

This book is the 2013 version of the catalog.

This issue contains information about new products like the Bottom Hole Assembly Tool (BHAT), Slip Lifting Tool (SLT), Landing String Slip (LSS), Master Bushing Heavy Duty (MBH), Landing String Bushing (LSB), several RST's, BX7, SBS, DSJX, BX4-35 etc.

### Patent info

Products in this catalog are covered by (but not limited to) the following patents:

US6,845,814 B2; WO03060280; US6,896,048; US 6,896,048; WO2005059299; GB2004/003413; US6,997,265 ; USSN 10/807,642; US2005/0216981; EP1475512; US6,443,241; US6,527,493; US6,691,801; US6,637,526; US6,938,709; WO.03/025444; WO.03/054338; WO2005045177; US6,82,632; WO2005106185; US7,510,006; US. 7,591,304

### Original instructions

The Original Instructions can be found on [www.nov.com/Drilling/Handling\\_Tools.aspx](http://www.nov.com/Drilling/Handling_Tools.aspx)

### Product information bulletins & safety alerts

All bulletins and alerts are available from [www.nov.com/Drilling/Handling\\_Tools.aspx](http://www.nov.com/Drilling/Handling_Tools.aspx)

### Liability

This catalog is intended to provide general information. Every effort has been made to ensure the accuracy of the information contained herein. NOV will not be held liable for errors in this material, or for consequences arising from misuse of this material.

### Copyright info

This publication is the property of, and contains information proprietary to NOV. No part of this publication may be reproduced or copied in any form, or by any means, including electronic, mechanical, photocopying, recording or otherwise, without the prior written permission of NOV.

Information in this catalog is subject to change without notice. This document and the information contained and represented herein is the copyrighted property of NOV-© 2013 National Oilwell Varco. All Rights Reserved.

Special information: Detailed descriptions of standard workshop procedures, safety principles and service operations are not included. Please note that this catalog may contain warnings about procedures which could damage equipment, make it unsafe, or cause PERSONAL INJURY. Please understand that these warnings cannot cover all conceivable ways in which service (whether or not recommended by NOV) might be done, or the possible hazardous consequences of each conceivable ways. Anyone using service procedures or tools, whether or not recommended by NOV, must be thoroughly satisfied that neither personal safety nor equipment safety will be jeopardized.

All information contained in this catalog is based upon the latest product information available at any time of printing. We reserve the right to make changes at any time without notice.

### Trademark info

NATIONAL, OILWELL, NATIONAL OILWELL VARCO, NOV, the NOV logo, EMSCO, IDECO, SKYTOP BREWSTER, CE, GRANT PRIDECO, PERFECTION, BOREMATCH, BAASH ROSS, VARCO BJ, and DYNAPLEX are trademarks of National Oilwell Varco, L.P. or its associated and affiliated companies.

### Conventions; Notes, Cautions, and Warnings

Notes, cautions, and warnings provide readers with additional information, and to advise the reader to take specific action to protect personnel from potential injury or lethal conditions. They may also inform the reader of actions necessary to prevent equipment damage. Please pay close attention to these advisories.

 **WARNING:** A warning indicates a definite risk of equipment damage or danger to personnel. Failure to observe and follow proper procedures could result in serious or fatal injury to personnel, significant property loss, or significant equipment damage.

 **CAUTION:** A caution indicates that potential damage to equipment or injury to personnel exists. Follow instructions explicitly. Extreme care should be taken when performing operations or procedures preceded by this caution.

**NOTE:** A note indicates that additional information is provided about the current topics.

### Illustrations

Illustrations (figures) provide a graphical representation of equipment components or screen snapshots for use in identifying parts or establishing nomenclature, and may or may not be drawn to scale.

## Safety requirements

NOV equipment is installed and operated in a controlled drilling rig environment involving hazardous situations. Proper maintenance is important for safe and reliable operation. Procedures outlined in NOV User Manuals are the recommended methods of performing operations and maintenance

 **WARNING: To avoid injury to personnel or equipment damage, carefully observe requirements outlined in this section.**

## General system safety practices

 **WARNING: Read and follow the guidelines below before installing equipment or performing maintenance to avoid endangering exposed persons or damaging equipment.**

- Isolate energy sources prior to beginning work.
- Avoid performing maintenance or repairs while the equipment is in operation.
- Wear proper protective equipment during equipment installation, maintenance, or repair.
- Never weld on any parts of tools. The tools are produced from cast alloy heat threaded steel or forged material and must not be welded in the field. Improper welding can cause cracks and brittleness in heat affected area's which result in weakening of the part and possible failure. Forgings should never be welded.

## Personnel Training

All personnel performing installation, operations, repair, or maintenance procedures on the equipment, or those in the vicinity of the equipment, should be trained on rig safety, tool operation, and maintenance to ensure their safety.

 **WARNING: Personnel should wear PPE's during installation, maintenance and operations.**  
Contact the NOV training department for more information about equipment operation and maintenance training.

## Recommended Tools

Service operations may require the use of tools designed specifically for the purpose described. NOV recommends that only those tools specified be used when stated. Ensure that personnel and equipment safety are not jeopardized when following service procedures or using tools not specifically recommended by NOV.

## Replacing Components

Verify that all components (such as cables, hoses, etc.) are tagged and labeled during assembly and disassembly of equipment to ensure correct installation. Replace failed or damaged components with NOV certified parts. Failure to do so could result in equipment damage or injury to personnel.

## Routine Maintenance

Equipment must be maintained on a routine basis. See the Users Manuals for maintenance recommendations.

 **WARNING: Failure to conduct routine maintenance could result in equipment damage or injury to personnel.**

## Proper Use of Equipment

NOV equipment is designed for specific functions and applications, and should be used only for its intended purpose.

## Lifting

The lifting procedures should carefully be observed and carried out according to the Original Instructions / Users Manuals.

## Limitations

The tools are designed to be used in the gas and oil well drilling environment, and must not be used for any other purpose.

## Abbreviations

Abbr.	Explanation	Abbr.	Explanation
AO	Air Operated	m	meter(s)
CL	Center Latch	mm	millimeter(s)
Csg	Casing	max.	Maximum
°C	Degree Celsius or Centigrade	min.	Minimum
DC	Drill Collars	Nm	Newton meter (= torque)
dia.	diameter	no.	number
DP	Drill Pipe	OD	outside diameter
EU	External upset	oz	ounce(s)
Elev.	Elevator	P/N	part number
°F	Degree Fahrenheit	psi	pounds per square inch
ft	foot or feet	qty.	quantity
ft.lbs	foot pounds (= torque)	rpm	rotation per minute
gpm	(US) gallon per minute	sTon	short ton (American ton)
hex	hexagon or hexagonal	sq	square
ID	inside diameter	SD	Side Door
in.	inch(es)	Tbg	Tubing
IEU	Internal external upset	Tonne	Ton (Metric ton)
IU	Internal upset	w/	with
kW	kilowatt	w/o	without
kPa	kilopascal	wt	weight
kg	kilogram(s)	w/Zip	with Zip groove
lb	pound(s)		

## Conversions

Metric conversions through-out this handbook conform to the Systeme Internationale (SI) metric equivalents.

### Metric to US

inches = millimeters / 25.4

feet = meters / 0.3048

pounds = kilograms / 0.4536

ounces = kilograms / 0.0283

sTon (short ton) = Metric Ton / 0.9072

### US to Metric

millimeter (mm) = inches x 25.4

meter (m) = feet x 0.3048

kilogram (kg) = pounds x 0.4536

kilogram (kg) = ounces x 0.0283

metric Ton (Tonne) = sTon x 0.9072

# TABLE OF CONTENTS

## TABLE OF CONTENTS

GENERAL INFORMATION	1
TABLE OF CONTENTS	5
POWER TOOLS	9
HK20000 POWER CASING TONG	10
SSW30 HYDRAULIC SPINNING WRENCH	11
SSW40 Pneumatic SPINNING WRENCH	11
KS6600 PNEUMATIC KELLY SPINNER	12
KS6800 HYDRAULIC KELLY SPINNER	12
TW61 HYDRAULIC TORQUE WRENCH	12
HYDRAULIC POWER UNITS & CONTROL PANELS	13
HYDRAULIC POWER UNIT	14
HYDRAULIC STAND ALONE CONTROL PANEL BX/BXS	16
FMS CONTROL PANEL	17
FMS375 Interlock assembly	17
CRT350/500 INTERLOCK PANEL	18
DYNAPLEX HOOKS	19
DYNAPLEX HOOKS	20
LINKS	23
WELDLESS LINKS	24
PERFECTION LINKS	26
DC DOLLY	27
ELEVATOR SELECTION CHARTS	29
ELEVATOR/PIPE MATCHING TOOL	30
ELEVATOR SELECTION CHARTS	31
ELEVATOR BORE CHARTS	33
HOW TO USE THE BORE CHARTS	34
DRILL PIPE BORE CODES	35
DRILL COLLARS WITH ZIP LIFT RECESS BORE CHART	36
PLAIN DRILL COLLARS WITH LIFT PLUGS BORE CHART	36
TUBING BORE CHART	37
COLLAR TYPE DRILL PIPE	37
BORE CHART	37
CASING BORE CHART	37
MANUAL & AIR OPERATED ELEVATORS	39
MANUAL OPERATED ELEVATORS	40
AIR OPERATED ELEVATORS	40
SLIP TYPE ELEVATORS	40
SLIP TYPE ELEVATORS MYC, YC & HYC SERIES	40
SLIP TYPE ELEVATORS YT, MYT & HYT SERIES	42
COLLAR TYPE ELEVATORS A SERIES	43
18° TYPE ELEVATORS G SERIES	44
X SERIES SIDE DOOR ELEVATORS	45
SJL & SPL SERIES ELEVATORS	46
SBX7, SJX & D-SJX SERIES ELEVATORS	48
SJH SERIES MANUAL ELEVATOR	50
HYDRAULIC ELEVATORS	51
BX HYDRAULICALLY ACTUATED ELEVATOR AND UNIVERSAL ROTATOR	52
BX HYDRAULICALLY ACTUATED ELEVATOR	53
ROTATORS	53
HYDRAULIC PICK UP ELEVATOR	59

<b>FMS + ELEVATOR / SPIDERS</b>	<b>61</b>
VARCO / BJ TYPE ELEVATOR/SPIDERS & FMS FLUSH MOUNTED SLIPS	62
BJ TYPE ELEVATOR/SPIDER 7.5/8" 250 TON & FMS275 FLUSH MOUNTED SLIP	64
BJ TYPE ELEVATOR/SPIDER 13.5/8" 350 TON	65
VARCO TYPE ELEVATOR/SPIDER 14" 500 TON & FMS375 FLUSH MOUNTED SLIP	66
VARCO TYPE ELEVATOR/SPIDER 24.1/2" 500 TON	68
VARCO TYPE ELEVATOR/SPIDER 14" 750 TON	69
VARCO TYPE ELEVATOR/SPIDER 24.1/2" 750/1000 TON	70
<b>POWER SLIPS</b>	<b>71</b>
PS21 and PS30 HYDRAULIC POWER SLIP	72
PS15 AND PS16 POWER SLIPS	76
PSF POWER SLIP FRAME &	77
SLT SLIP LIFTING TOOL	77
BHAT BOTTOM HOLE ASSEMBLY TOOL	78
<b>BUSHINGS / SLIPS / CLAMPS</b>	<b>79</b>
CU, CUL AND CB CASING BUSHINGS	80
CASING SPIDERS	81
UC-3 CASING SLIPS	81
ROLLER KELLY BUSHINGS	82
KELLY BUSHINGS	83
MPCH MASTER BUSHING	83
MSPC MASTER BUSHING	83
MSP MASTER BUSHINGS	83
MBH1250 HINGED MASTER BUSHING	85
LIFTING SLINGS	87
LIFTING SLINGS	87
ROTARY SLIPS, CASING SLIPS	88
CIRCULAR BUTTONS	89
FLEX HANDLES	90
MULTIPURPOSE SAFETY CLAMP	91
<b>MANUAL TONGS</b>	<b>93</b>
MANUAL TONGS	94
<b>CASING RUNNING TOOLS</b>	<b>99</b>
CRT350 & CRT500 CASING RUNNING TOOL	100
<b>ROTARY SUPPORT TABLES</b>	<b>111</b>
RST ROTARY SUPPORT TABLE	112
SST STATIC SUPPORT TABLE	113
<b>ADAPTER RINGS</b>	<b>115</b>
ADAPTER RINGS	116



# TABLE OF CONTENTS

# POWER TOOLS

## HK20000 POWER CASING TONG

The HK20000 power casing tong is a tool designed for making up and breaking casing.

The rotor support design has the cam followers attached directly to the rotor, providing support for a smooth and quiet operation. A priority 4-way valve minimizes possible gear train damage. The power assisted gear shift assures efficient operation. Accommodations for torque return are standard. A load cell and torque gauge are available as accessories. A two-speed gear box uses a cluster gear, high and low speed gears and pinion shaft. The single door design is simple to operate and has fixed guide support for the rotor. The door interlock system increases safety as the tong will not rotate with the door open. A single hanging bar arrangement is easier to adjust and provides maximum clearance making the HK20000 power casing tong safe to work with.

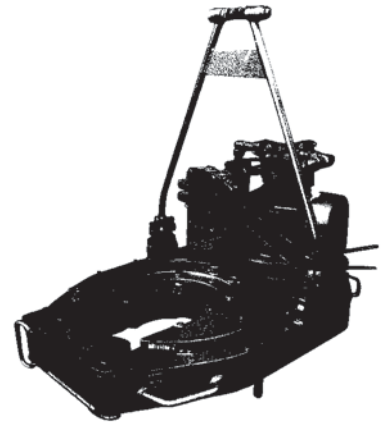

### TECHNICAL SPECIFICATIONS

Description	Imperial	Metric
Size range	4" – 14"	102-356 mm
Torque low gear	20,000 ft.lbs @ 2300 psi	27,000Nm @ 15,857 kPa
Torque high gear	4,900 ft.lbs @ 2300 psi	6,650 Nm @ 15,857 kPa
Maximum intermittent torque	25,000 ft.lbs @ 2,500 psi	34,000 Nm @ 17,237 kPa
Rpm in low gear	17 rpm	17 rpm
Rpm in high gear	70 rpm	70 rpm
Power requirements: Volume	66 gpm @ 1,000 psi	250 ltr/ min @ 7,000 kPa
Pressure (max.)	2,500 psi	17,237 kPa
Dimensions (L x W x H)	62" x 37" x 54"	1,571 x 940 x 1372 mm
Torque arm length back-up eye to center line of pipe	39"	1,007 mm
Weight	1,950 lbs	886 kg

### MAIN PART NUMBERS

Description	Part number
Main assembly	8532-5000-10

### OPTIONAL EQUIPMENT PART NUMBERS

Description	Part number
Suspension spring assembly	8532-5108
Tong torque assembly	8532-5119

### SIZE EQUIPMENT

Pipe Size	Part number Jaw Assembly (2 pc)	Part number Guide ring (1 pc)	Pipe Size	Part number Jaw Assembly (2 pc)	Part number Guide ring (1 pc)
3.1/2"	200708-1		7"	8547-5026	
4"	50006093-1	201107-6	7.5/8"	8547-5027	201107-3
4.1/2"	8547-5211		8.5/8"	8547-5028	
4.3/4"	8547-5205		9.5/8"	8547-5029	
5"	8547-5206	201107-1	10.3/4"	8547-5030	201107-4
5.1/2"	8547-5207		11.3/4"	8547-5031	
5.3/4"	200692		12"	8547-5032	
6"	8547-5208		12.3/4"	200690	
6.3/8"	200688-1	201107-2	13.3/8"	8547-5033	n/a
6.5/8"	8547-5209		14"	8547-5034	
6.7/8"	200689-1				

## SSW30 HYDRAULIC SPINNING WRENCH SSW40 PNEUMATIC SPINNING WRENCH

The hydraulically powered SSW30 can spin drill pipe and drill collars from 2.7/8" to 9.1/2" O.D. with no adjustments necessary. Its abundant power will bump up shoulders tight enough so each joint is quickly torqued.

This lightweight tool is narrower and has lower profile than previous spinning wrench designs. It achieves its compact shape by using one large cylinder for clamping.

The pneumatically powered SSW40 can spin drill pipe and drill

An easy adjustment screw eliminates the need to change rollers and can accommodate drill pipe and drill collars from 3.1/2" to 9.1/2" OD. The speed of the SSW40's four drive rollers, powered by two motors, is precisely controlled by the operator to permit the slow walking in of drill collars or fast spinning in or out when tripping pipe.



SSW30



SSW40

### TECHNICAL SPECIFICATIONS SSW30

Description	Imperial	Metric
Size range	2.7/8" - 9.1/2" OD	73-241 mm OD
Normal operating hydraulic pressure	2,000 psi	13,789 kPa
Torque (5" dia. pipe)	900 to 1,000 ft.lbs	1,215-1,350 Nm
Rpm (5" dia. pipe)	100 rpm @ 5" pipe	100 rpm @ 125 mm pipe
Weight	990 lbs	449 kg
Hydraulic power requirement	28 to 45 gpm	106 to 170 lpm

### TECHNICAL SPECIFICATIONS SSW40

Description	Imperial	Metric
Size range	3.1/2" - 9.1/2"	89-241 mm
Air pressure Min/Max:	90 - 125 psi	620 - 860 kPa
Max. air consumption:	250 cfm	530 dm <sup>3</sup> /s
Max. stall torque (5" dia. pipe):	1,100 ft.lbs	1,490 Nm
Weight:	780 lbs	353 kg

### MAIN PART NUMBERS

Description	Part number
SSW30 Closed center	19000-6
SSW30 Open center	19000-7
SSW40	73109

### OPTIONAL EQUIPMENT PART NUMBERS SSW30

Description	Part number
Pressure hose 25 ft	58314-25
Pressure hose 50 ft	58314-50
Return hose 25 ft	58518-25
Return hose 50 ft	58518-50
Plug G3/4 for SD25 for closed center operation	n/a

\*Specify length 6; 15; 25; 35 or 50 feet

## KS6600 PNEUMATIC KELLY SPINNER KS6800 HYDRAULIC KELLY SPINNER

The KS6600 and KS6800 Kelly Spinners can be used for rotating drill pipe slowly, for limited rathole and mousehole drilling and making fast kelly connections. These units are completely reversible; the driller can spin-out, as well as spin-in, when making connections, therefore, spinning chains are not required.



### TECHNICAL SPECIFICATIONS

Description	Imperial	Metric
Connections	6.5/8" API Reg LH	168.275 mm API Reg LH
Height	38.1/2"	978 mm
Diameter	28"	711 mm
Weight	1,110 Lbs	504 kg
Stall torque	1,200 ft.lbs	1,627 Nm
Rpm	110 rpm	110 rpm
Air flow (KS6600)	320 cfm	680 dm <sup>3</sup> /s
Hydraulic flow (KS6800)	24 gpm	91 lpm
Rotation	Right and Left	Right and Left

### MAIN PART NUMBERS

Part number	Assembly description
70876Y	Pneumatic Kelly Spinner KS6600 complete with thread protectors, control valve, filter lubricator, and 62 foot hoses:
70877Y	Same as above with 77 foot hoses:
70867Y	Hydraulic Kelly Spinner KS6800 complete with thread protectors, control valve, filter lubricator, and 62 foot hoses:
70868Y	Same as above with 77 foot hoses:

## TW61 HYDRAULIC TORQUE WRENCH

The NOV TW61 hydraulic torque wrench makes-up and breaks-out drill pipe and drill collars from 4" to 8.1/2" OD. Torque is adjustable and can be pre-set to the required value. Upper and lower gripping structures provide the required torque. The TW61 wrench can rotate the tool joint pin up to 34°, to produce the desired torque while providing its own back-up. A built-in tigger is provided to pull the TW61 wrench back out of the way while lowering or raising pipe stands. The tigger can also be used to assist in pulling the TW61 wrench to a storage position. The tool has 6-foot vertical travel.

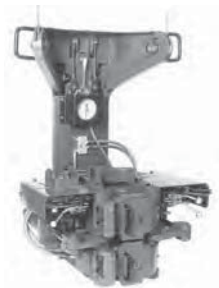

### TECHNICAL SPECIFICATIONS

Description	Imperial	Metric
Size	4" - 8.1/2"	102-216 mm
Make-up Torque	63,000 ft.lbs	85,000 Nm
Break-out Torque	75,000 ft.lbs	101,000 Nm
Power Requirements	30-35 gpm @ 2,000 psi	114-133 lpm @13,789 kPa
Air Pressure (for Tigger)	90-125 psi	620-860 kPa
Weight	3,190 lbs	1,450 kg
Vertical Positioning (Total travel)	72"	1,830 mm
Rate of Travel	2" / s	50.8 mm / s
Cycle Time	@ 40 gpm	@ 151 lpm
Clamping Both Jaws	2.5 s	2.5 s
Clamping Upper Jaw	1.25 s	1.25 s
Torquing 34°	2 s	2 s

### MAIN PART NUMBER

Part number
19999-12

# HYDRAULIC POWER UNITS & CONTROL PANELS

## HYDRAULIC POWER UNIT

### HKB (CE + ATEX EXPLOSION PROOF) power units

Since the introduction of the HKB35 and HKB66 hydraulic power units, NOV has continuously worked towards improving the efficiency, reliability and safety of these designs. This expanded product range will respond to the industry demands for reliable easy maintenance power units built according to ATEX-rules (Explosion Safety) for safer operation.

#### HKB FEATURES

- Variable displacement piston pump which stops the flow at maximum pressure to prevent unnecessary heating up of the oil.
- A power compensator is mounted to prevent an overload of the electric motor
- Automatic temperature control. The cooler starts automatically at an oil temperature inside the tank of 38°C (100°F). The unit automatically shuts down if the oil temperature inside the tank reaches 70°C (158°F)
- Automatic oil level safety. Unit automatically shuts down if the oil level inside the tank is too low.
- Pressure and return connections with quick disconnect couplings
- Electric powered
- Skid mounted unit can be lifted using a forklift or crane
- HKB units can be lifted using a forklift or a crane.
- Maximum pressure 2500 psi (175 bar)
- Return line equipped with contamination indicator

#### OPTIONS

- Available in various pressure and flow configurations
- Available for standard, arctic and desert ambient temperatures.
- Available in 50 or 60Hz, from 360 to 480 Volts. Other supply power on request.
- Diesel HKB's on request.
- Available with remote starter kit
- Available HKB140D dual pump with a secondary pump for 100% redundancy.
- Air-over-Hydraulic Power Unit HKB3

#### ATEX: EXPLOSION SAFETY

- HKB units are built according requirements of the European directive EN 982 and EN 94/9/EC for use in potentially explosive atmosphere.
- Standard ATEX compliance according to Ex II 2G T3 EEx-e IIB T3 for use in zone 2 (category 3) as a minimum.

#### FLOW AND PRESSURE

- Fixed pressure - Fixed flow (standard)
- Fixed pressure - Adjustable flow
- Adjustable pressure - Adjustable flow
- Adjustable pressure - Fixed flow

#### AMBIENT TEMPERATURE

- -10° to +40°C (standard)
- 0° to 50° C (Desert)
- -40° to + 10°C (Arctic)

#### POWER SUPPLY

- 360 up to 480 V
- 50 or 60 Hz



## HKB3 POWER AIR-OVER-HYDRAULIC POWER UNIT

The HKB-3 unit is an air driven hydraulic power unit which supplies hydraulic fluid under pressure to the FMS.

### PART NUMBERS HKB3

- 50007090 HKB3
- 50007091 HKB3 with remote control

## QUICK REFERENCE FOR EXISTING TOOLS

### ORDERING INFORMATION

To order the HKB with the proper specifications, choose from different flow settings, temperatures listed.

HKB	Tool interface	Required pressure [psi/ kPa]	Required flow [gpm/ lpm]	Available units	
				50Hz	60Hz
71	FMS375	2,000 / 13,790	5/18.9	No	Yes
71	PS21/30	2,500 / 17,240	10/38	Yes	Yes
71	BX3,4,5,S	2,000 / 13,789	7/26.5	Yes	Yes
71	H-SJH	2,000 / 13,789	5/18.9	Yes	Yes
71	All E/S's	2,000 / 13,789	12/45	Yes	Yes
71	FMS275	2,000 / 13,789	12/45	Yes	Yes
71	CRT350	2,000 / 13,789	16/60	Yes	Yes
71	CRT500	2,000 / 13,789	16/60	Yes	Yes
100	KS6800	2,000 / 13,790	24/91	Yes	Yes
100	TW61	2,000 / 13,790	35/132	Yes	Yes
140	SSW30	2,000 / 13,790	45/170	Yes	Yes
100	FMS375	2,000 / 13,790	32/121	Yes	No
100	ST80	2,000 / 13,790	45/151	Yes	Yes
140	IR2100	2,000 / 13,790	32/121	Yes	Yes
140	SSW30	2,000 / 13,790	45/170	Yes	Yes
140	HK20000	2,500 / 17,240	66/250	No	Yes
180	HK20000	2,500 / 17,240	66/250	Yes	No
180	ST100	2,500 / 17,240	66/250	Yes	No
140D	TDS+AR3200	2,500 / 17,240	66/250	Yes	Yes
HKB3	FMS375	2,000 / 13,790	32/121	n/a	n/a

## SELECTING THE HKB POWER UNIT\*

### HKB71

- Pump 71 cc/rev
- Qmax at 1,500 rpm [50 Hz]: 106.5 lpm=27 gpm
- Qmax at 1,750 rpm [60 Hz]: 124 lpm=32 gpm
- Maximal pressure: 2,500 psi / 17,240 kPa
- Maximum power output: 15 kW
- Dimensions LxWxH [inches/m]: 78x43x60/2x1.1x1.5

### HKB100

- Pump 100 cc/rev
- Qmax at 1,500 rpm [50 Hz]: 150 lpm=38 gpm
- Qmax at 1,750 rpm [60 Hz]: 175 lpm=46 gpm
- Maximum pressure: 2,500 psi / 17,240 kPa
- Maximum power output: 22 kW
- Dimensions LxWxH [inches/m]: 79x43x60/2x1.1x1.5

### HKB140 + HKB 140 D (Dual pump for 100% redundancy, NOT for 2 pump operation)

- Pump 140 cc/rev
- Qmax at 1,500 rpm [50 Hz]: 210 lpm=53 gpm
- Qmax at 1,750 rpm [60 Hz]: 245 lpm=65 gpm
- Maximum pressure: 2,500 psi / 17,240 kPa
- Maximum output power: 30 kW
- Dimensions Single Pump LxWxH [inches/m]: 87x43x60/2.2x1.1x1.5

### HKB180

- Pump 180 cc/rev
- Qmax at 1,500 rpm [50 Hz]: 270 lpm=69 gpm
- Qmax bij 1,750 rpm [60 Hz]: 315 lpm=95 gpm
- Maximum pressure: 2,500 psi / 17,240 kPa
- Maximum output power: 37 kW
- Dimensions LxWxH [inches/m]: 95x43x60/2.4x1.1x1.5

### HKB3

- Pump 180 cc/rev
- Qmax: 7.5 lpm = 2 gpm
- Max "Slips down" pressure is preset at 2,500 psi / 17,200 kPa
- Max "Slips up" pressure is preset at 1,000 psi / 6,900 kPa
- Minimum airpressure 95 psi / 690 kPa
- Maximum airpressure 300 psi / 2,100 kPa
- Air consumption at input pressure 95 psi / 6,5 Bar / max. 75cfm / 2.12 m<sup>3</sup>/min
- Dimensions LxWxH [inches/mm]: 34 x 30 x 55.75 / 863.6 x 762 x 1416



Theoretical flow curves HKB power units

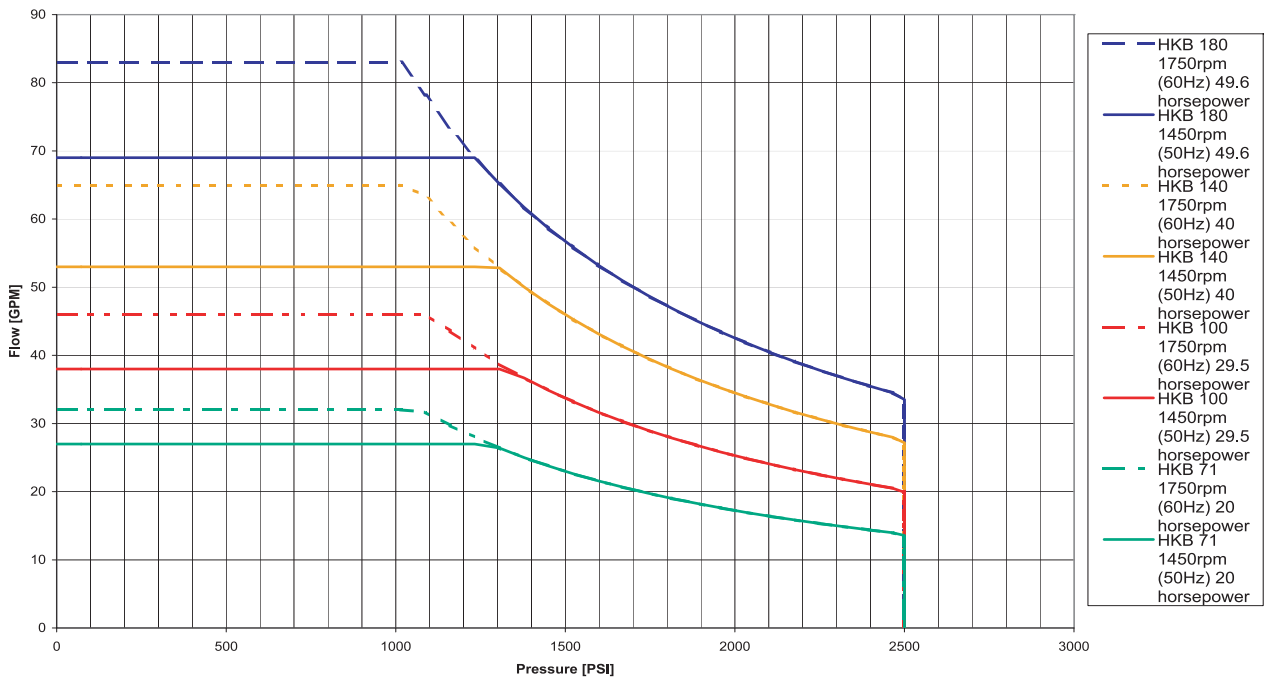

\*All data subject to confirmation by manufacturer

For details or a quotation, please contact NOV



## HYDRAULIC STAND ALONE CONTROL PANEL BX/BXS

Portable fully hydraulic control panel to operate BX and BXS tools through a portable service loop. Also suitable to operate the BX universal rotator.

The panel is suitable to operate the following rotary spiders/slips: FMS275, FMS375, PS21, PS30 and hydraulic Elevator / Spiders 14" & 24".

The panel has an interlock function between the elevator and the rotary spider (except FMS275 which can not be interlocked due to the lack of a Xp-signal).



### TECHNICAL SPECIFICATIONS

#### Weight & Dimensions of Panel

Weight Stand Alone Control Panel [lbs/kg]	450 / 200
Dimensions Overall: Height x Width x Depth [inches/mm]	47.5 x 27.6 x 19.7 / 1210 x 700 x 500

#### Weight & Dimensions of Service Loops

Service Loop is suitable for BX 3, 4 and 5 and BXS .

Service Loop is suitable for Universal Rotator (Single Arm, pn 50004130) ONLY

Length (Coupling to Coupling) [ft/m]	197 / 60
--------------------------------------	----------

Weight (Oil filled) [lbs/kg]	800 / 365
------------------------------	-----------

Service Loops is supplied with two loop hanger assemblies to provide interface point to the Derrick (via Tugger) and the Top-Drive (RLA Link-ear or other suitable attachment point).

### MAIN PART NUMBERS

Part number	Description
50000350	Control panel assembly
50000360	Service loop

### OPTIONAL EQUIPMENT PART NUMBERS

Part number	Description
50000350-13	1 year spares for control panel and service loop
200977-8	Hose kit for FMS375
50005249	Hose kit for FMS275
50008610-21	Hose kit for PS21
50008610-30	Hose kit for PS30

## FMS CONTROL PANEL

The FMS is connected to the panel by applying two hoses between the FMS and the two quick disconnect couplers (Slips up, Slips down) on the panel.

On the extra connections of the control panel (Pressure power tong, Return power tong) a power tong or secondary tool can be connected by using hydraulic hoses. This tool also needs to be an open center system.

The panel allows to control both the FMS and power tong. No power fluctuations will occur, allowing a consistent operation and reliable torque read out.



## TECHNICAL SPECIFICATIONS

Hydraulic characteristics	
Maximum pressure [psi/kPa]	3,000 / 20,684
Maximum flow [gpm/lpm]	50 / 190
Pressure at "pressure power-unit" connection [psi/kPa]	2,600-3,000 / 17,926-20,684
Back pressure at "return power unit" connection [psi/kPa]	0-200 / 0-1,378
Power unit flow range [gpm/lpm]	5-50 / 19-190
Pressure on "slips down" connection [psi/kPa]	1,300-2,450 / 8,963-16,892
Standard settings on "slips down" connection [psi/kPa]	1,800 / 12,410
Pressure on "slip up" connection [psi/kPa]	1,000 / 6,894
Max. output flow to FMS [gpm/lpm]	15 / 57
Output flow to pressure power tong	When the FMS slips are travelling; no flow is available. With the FMS stationary, see power unit flow range (minus leakage flow)
Nominal volume of accumulator [gallon/l]	0.18 / 0.7
Nitrogen pre-charge pressure [psi/kPa]	1,960 / 13,513
Maximum accumulator pressure [psi/kPa]	3,000 / 20,684
Pneumatic characteristics	
Pressure at air pressure connection [psi/kPa]	90-230 / 620-1585
Air flow [gpm/lpm]	396 / 1,500
Dimensions and weight	
Dimensions (L x W x H) [inches/mm]	29.53" x 22.83" x 21.65" / 750x580x55
Weight [lbs/kg]	265 / 120

## MAIN PART NUMBER

Part number	Description
50006538	Control panel

## FMS375 INTERLOCK ASSEMBLY

By using the FMS375 interlock assembly, it is possible to create an interlocking between an elevator (providing this elevator also has the possibility for interlocking). No need for an additional control panel is needed except for the standard panel P/N 50006538.

## MAIN PART NUMBER

Part number	Description
50008225	FMS375 Interlock Assembly

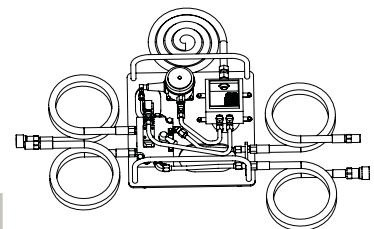

## CRT350/500 INTERLOCK PANEL

The CRT350/500 operator control panel contains all required valves and control handles to remotely operate the following tools:

- The CRT350 Casing Running Tool
- The CRT500 Casing Running Tool
- The CRT350 Casing Running Tool hydraulic single joint elevator (H-SJH)
- The CRT500 Casing Running Tool hydraulic single joint elevator (UX)
- The hydraulic rotary slips like FMS Flush Mounted Slips

The control panel connects to both the CRT350/ and the CRT500 and it's hydraulic single joint elevator H-SJH/UX (via the service loop) as well as the hydraulic rotary slips.

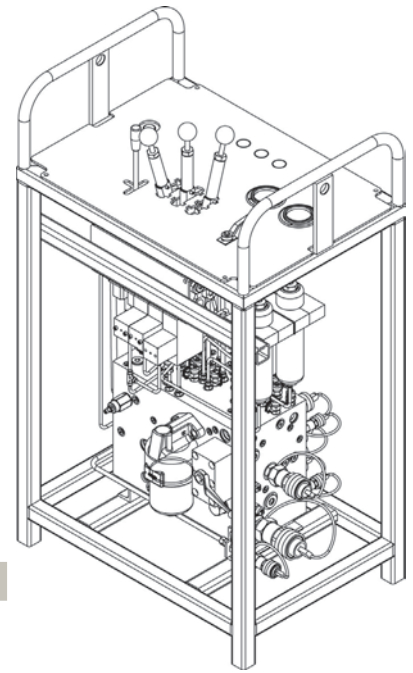

## TECHNICAL SPECIFICATIONS

### Dimensions and weight

Dimensions (L x W x H) [inches / mm]	27,6 x 19,7 x 47,5 / 675 x 500 x 1206
Weight [lbs / kg]	450 / 204

## MAIN PART NUMBERS

Part number	Description
50008610	Control panel
50008551	Service loop

## OPTIONAL EQUIPMENT PART NUMBERS

Part number	Description
50008610-13	1 year spares for control panel and service loop
200977-8	Hose kit for FMS375
50005249	Hose kit for FMS275
50008610-21	Hose kit for PS21
50008610-30	Hose kit for PS30

# DYNAPLEX HOOKS

## DYNAPLEX HOOKS

The Dynaplex hook is a premium-quality rotary hook for heavy-duty drilling requirements. Special features: hydraulic snubber, flexible pin connection and hook positioner. The hook positioner provides faster, safer operation and cuts down round-trip time. When going in the hole, the positioner automatically rotates the elevator into the correct position for the derrickman to catch the next stand of pipe. The positioner also prevents the hook and elevator from being rotated by the "spin-up" of drill pipe going in the hole. Operators may desire to direct-connect the Dynaplex hook to the traveling block.



### TECHNICAL SPECIFICATIONS

Specifications	51000	5750	5500	5350
Capacity [Tonne/sTon]	907 / 1,000	680 / 750	453 / 500	317 / 350
Hook complete with positioner [lbs]	38,320	31,108	26,955	24,767
Hook complete with positioner [kg]	17,385	14,110	12,227	11,193

### MAIN PART NUMBERS

Hook Model	Part number hook complete with positioner
51000	38327Y
5750	31108Y
5500	26955Y
5350	24767Y

### DIMENSIONAL DATA DYNAPLEX HOOKS - BLOCK COMBINATIONS

\*information on request

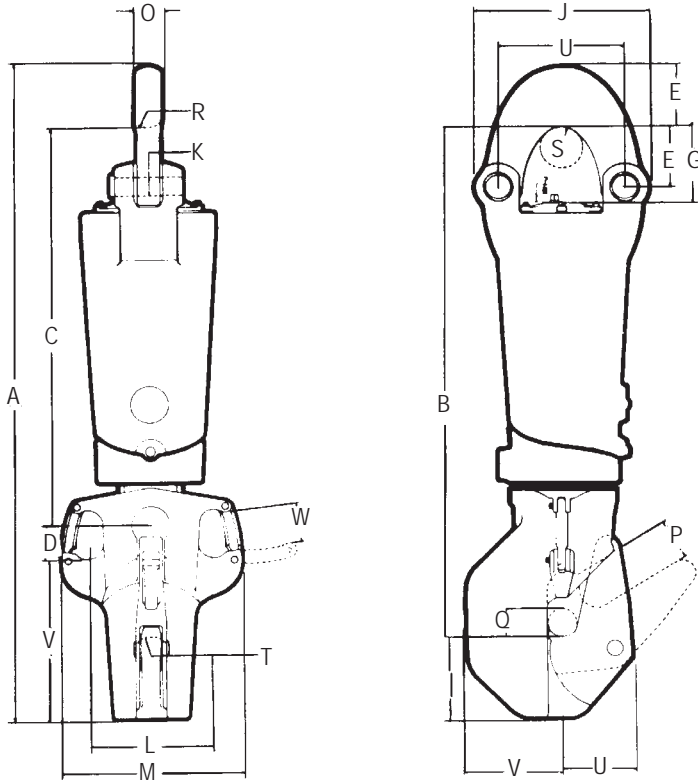

Ref.	51000		5750		5500		5350	
No.	[inches]	[mm]	[inches]	[mm]	[inches]	[mm]	[inches]	[mm]
A*	187.3/4	4768.85	162	4114.80	139.1/2	3543.30	126.3/4	3219.45
B*	150.7/8	3832.23	129.1/2	3289.30	109.3/8	2778.13	97.1/2	2476.50
C*	118.3/4	3016.25	102.1/2	2604.00	85.3/8	2168.53	72.5/8	1844.68
D	6.5/8	168.28	6.5/16	160.34	7.3/8	187.33	9	228.60
E	15.1/2	393.70	13.1/2	342.90	12.1/2	317.50	11	279.40
F	17.1/2	444.50	15	381.00	13	330.20	11.1/4	285.75
G	23.3/8	594.00	20	508.00	16.5/8	422.28	14	355.60
H	41	1041.40	35.1/4	895.35	26.1/4	666.75	21	533.40
I	21.3/8	542.93	19	482.60	17.3/4	450.85	18.1/4	463.55
J	56.1/2	1435.10	48.1/4	1225.55	36.1/2	927.10	29.3/4	755.65
K	6.1/2	165.10	5.3/4	146.05	4	101.60	3.1/4	82.55
L	36.3/4	933.45	32.1/4	819.15	26.3/4	679.45	22	558.80
M	48.3/4	1238.25	43.1/2	1104.90	37.3/4	958.85	30.3/4	781.05
N	46.7/8	1190.63	39.11/16	1008.06	34.1/4	869.95	34.1/8	866.78
O	9	228.60	7	177.80	6.1/2	165.10	5.3/8	136.53
P	12.1/2	317.50	10.3/4	273.05	8.1/2	215.90	7.1/2	190.50
Q	10.1/2	266.70	8.1/2	215.90	7	177.90	6.1/2	165.10
R	6	152.40	3.1/4	82.55	3.1/4	82.55	3	76.20
S	6	152.40	6	152.40	4.1/2	114.30	4	101.60
T	5	127.00	4	101.60	4	101.60	4	101.60
U	18.7/8	479.43	16	406.40	14.1/4	361.95	13.1/4	336.50
V	25.5/8	650.88	22.1/2	571.50	20.3/8	517.53	19	482.60
W	9	228.60	8	203.20	8.1/4	209.55	6	152.40

\* Add for Spring Travel 8"



# LINKS



## WELDLESS LINKS

Weldless links are forged from a single piece of high-grade alloy steel to provide maximum tensile strength. More weight and "plus-diameter" in critical areas make these links extra strong. Short upper eye design means better balance and easier elevator handling, while reducing wear of the eye section against the swivel bail or body.

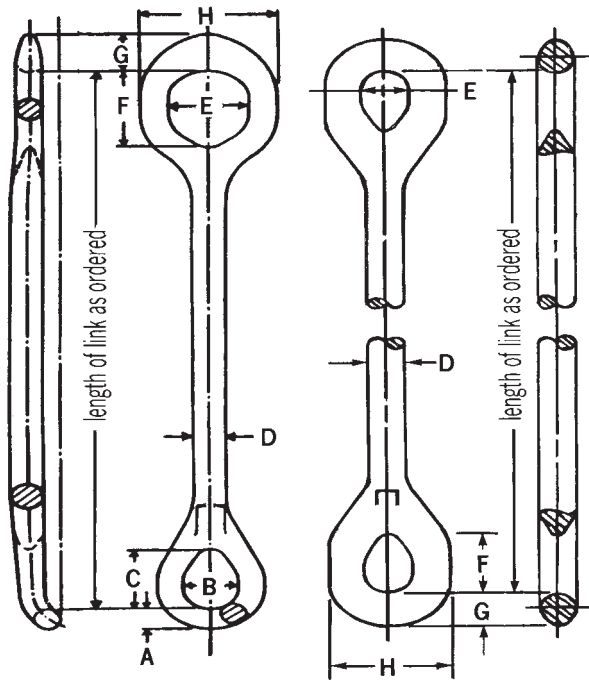

Weldless links 2.1/4" - 3.1/2"

Weldless links 4.3/4" - 5.1/2"



## TECHNICAL SPECIFICATIONS\*

Link type	Nominal [inches]	Dim.	A	B	C	D	E	F	G	H
250 [sTon]	2.1/4	[inches]	2.5/16"	5.1/2"	7.1/2"	2.7/8"	9.1/2"	12"	5"	15"
"	"	[mm]	58.7	139.7	190.5	73	241.3	304.8	127	381
350 [sTon]	2.3/4	[inches]	2.13/16"	5.5/8"	8.3/8"	3.1/2"	9.1/2"	12"	5"	15"
"	"	[mm]	71.4	142.9	212.7	88.9	241.3	304.8	127	381
500 [sTon]	3.1/2	[inches]	3.5/8"	6.1/2"	10.1/8"	4.1/2"	9.1/2"	12"	6"	17"
"	"	[mm]	92.1	165.1	257.2	114.3	241.3	304.8	152.4	431.8
750 [sTon]	4.3/4	[inches]	na	na	na	6"	10"	14.5/8"	7.1/2"	23"
"	"	[mm]	na	na	na	152.4	254	371.5	190.5	584.2
1,000 [sTon]	5.1/2	[inches]	na	na	na	6"	12.3/4"	17.1/2"	8.1/4"	29.1/4"
"	"	[mm]	na	na	na	152.4	323.9	444.5	209.6	743
1,250 [sTon]	5.1/2	[inches]	na	na	na	6"	12.3/4"	17.1/2"	8.1/4"	29.1/4"
"	"	[mm]	na	na	na	152.4	323.9	444.5	209.6	743
1,500 [sTon]	5.1/2	[inches]	na	na	na	6.606"	12.3/4"	17.1/2"	10"	30"
"	"	[mm]	na	na	na	167.8	323.9	444.5	254	743

\* Note: The dimensions are nominal. The actual dimensions may vary due to manufacturing tolerances. All API contact radius are manufactured according to API specifications.

## PART NUMBERS WELDLESS LINKS

Part number	Nominal link size [inches]	Size [inches/mm]	Load rating per set [sTon/Tonne]	Weight per Set [lbs/ kg]
16363Y1060	2.1/4 x 60	60 / 1,524	250 / 226.8	480 / 218
16363Y1072	2.1/4 x 72	72 / 1,829	250 / 226.8	530 / 241
16363Y1084	2.1/4 x 84	84 / 2,134	250 / 226.8	580 / 264
16363Y1096	2.1/4 x 96	96 / 2,438	250 / 226.8	630 / 286
16363Y1108	2.1/4 x 108	108 / 2,743	250 / 226.8	680 / 309
16363Y1132	2.1/4 x 132	132 / 3,353	250 / 226.8	780 / 355
16363Y1168	2.1/4 x 168	168 / 4,267	250 / 226.8	880 / 399
26940Y1060	2.3/4 x 60	60 / 1,524	350 / 317.5	620 / 282
26940Y1072	2.3/4 x 72	72 / 1,829	350 / 317.5	685 / 311
26940Y1084	2.3/4 x 84	84 / 2,134	350 / 317.5	740 / 336
26940Y1096	2.3/4 x 96	96 / 2,438	350 / 317.5	805 / 366
26940Y1108	2.3/4 x 108	108 / 2,743	350 / 317.5	870 / 395
26940Y1120	2.3/4 x 120	120 / 3,048	350 / 317.5	935 / 425
26940Y1132	2.3/4 x 132	132 / 3,353	350 / 317.5	1,000 / 454
26940Y1144	2.3/4 x 144	144 / 3,657	350 / 317.5	1,064 / 483
26940Y1150	2.3/4 x 150	150 / 3,810	350 / 317.5	1,095 / 498
26940Y1168	2.3/4 x 168	168 / 4,267	350 / 317.5	1,190 / 541
26940Y1180	2.3/4 x 180	180 / 4,572	350 / 317.5	1,255 / 571
26940Y1192	2.3/4 x 192	192 / 4,877	350 / 317.5	1,320 / 600
26940Y1200	2.3/4 x 200	200 / 5,080	350 / 317.5	1,363 / 618
26940Y1216	2.3/4 x 216	216 / 5,486	350 / 317.5	1,450 / 659
26940Y1240	2.3/4 x 240	240 / 6,096	350 / 317.5	1,580 / 718
26940Y1264	2.3/4 x 264	264 / 6,705	350 / 317.5	1,770 / 800
26940Y1290	2.3/4 x 290	290 / 7,366	350 / 317.5	1,944 / 882
26940Y1350	2.3/4 x 350	350 / 8,890	350 / 317.5	2,180 / 988
26940Y1360	2.3/4 x 360	360 / 9,144	350 / 317.5	2,235 / 1,014
26940Y1480	2.3/4 x 480	480 / 12,192	350 / 317.5	2,885 / 1,306
26940Y1540	2.3/4 x 540	540 / 13,716	350 / 317.5	3,187 / 1,446
26940Y1600	2.3/4 x 600	600 / 15,240	350 / 317.5	3,408 / 1,546
25469Y1072	3.1/2 x 72	72 / 1,829	500 / 453.6	705 / 320
25469Y1096	3.1/2 x 96	96 / 2,438	500 / 453.6	1058 / 480
25469Y1108	3.1/2 x 108	108 / 2,743	500 / 453.6	1,450 / 659
25469Y1120	3.1/2 x 120	120 / 3,048	500 / 453.6	1,622 / 736
25469Y1132	3.1/2 x 132	132 / 3,353	500 / 453.6	1,670 / 759
25469Y1144	3.1/2 x 144	144 / 3,688	500 / 453.6	1,780 / 809
25469Y1160	3.1/2 x 160	160 / 4,064	500 / 453.6	1,927 / 876
25469Y1168	3.1/2 x 168	168 / 4,267	500 / 453.6	2,000 / 909
25469Y1180	3.1/2 x 180	180 / 4,572	500 / 453.6	2,110 / 959
25469Y1190	3.1/2 x 190	190 / 4,826	500 / 453.6	2,202 / 998
25469Y1192	3.1/2 x 192	192 / 4,826	500 / 453.6	2,220 / 1,007
25469Y1216	3.1/2 x 216	216 / 5,486	500 / 453.6	2,422 / 1,098
25469Y1226	3.1/2 x 226	226 / 5,740	500 / 453.6	2,596 / 1,177
25469Y1264	3.1/2 x 264	264 / 6,706	500 / 453.6	2,882 / 1,307
25469Y1360	3.1/2 x 360	360 / 9,144	500 / 453.6	3,174 / 1,440
25469Y1480	3.1/2 x 480	480 / 12,192	500 / 453.6	3,968 / 1,800
25469Y1540	3.1/2 x 540	540 / 13,716	500 / 453.6	4,519 / 2,050

\* for TDS-4 & TDS-5 top drives

Part number	Nominal link size [inches]	Size [inches/mm]	Load rating per set [sTon/Tonne]	Appr. weight per Set [lbs/kg]
16143Y1132	4.3/4 x 132	132 / 3,352	750 / 680.4	1,741 / 790
16143Y1144	4.3/4 x 144	144 / 3,688	750 / 680.4	2,312 / 1,051
16143Y1160	4.3/4 x 160	160 / 3,688	750 / 680.4	3,178 / 1,445
16143Y1180	4.3/4 x 180	180 / 4,572	750 / 680.4	3,900 / 1,769
16143Y1200	4.3/4 x 200	200 / 5,080	750 / 680.4	4,550 / 2,063
16143Y1216	4.3/4 x 216	216 / 5,486	750 / 680.4	5,200 / 2,364
16143Y1240	4.3/4 x 240	240 / 6,096	750 / 680.4	5,864 / 2,660
16143Y1264	4.3/4 x 264	264 / 6,705	750 / 680.4	7,275 / 3,300
16143Y1300	4.3/4 x 300	300 / 7,620	750 / 680.4	8,800 / 3,991

70101Y1200*	5.1/2 x 200	200 / 5,080	1,000 / 907.2	5,100 / 2,315
10392589-23	5.1/2 x 180	200 / 5,080	1,250 / 1,133	4,550 / 2,063
10392589-008	5.1/2 x 200	200 / 5,080	1,250 / 1,133	5,100 / 2,315
10392589-012	5.1/2 x 240	200 / 5,080	1,250 / 1,133	7,275 / 3,300

Part number	Nominal link size [inches]	Size [inches/mm]	Load rating per set [sTon/Tonne]	Appr. weight per Set [lbs/kg]
10730284-180	5.1/2 x 180 PSL1	180	1,500 / 1,360	3,900 / 1,769
10738399-180	5.1/2 x 180 PSL2	180	1,500 / 1,360	3,900 / 1,769
10730284-200	5.1/2 x 200 PSL1	200	1,500 / 1,360	4,550 / 2,063
10738399-200	5.1/2 x 200 PSL2	200	1,500 / 1,360	4,550 / 2,063
10730284-240	5.1/2 x 240 PSL1	240	1,500 / 1,360	7,275 / 3,300
10738399-240	5.1/2 x 240 PSL2	240	1,500 / 1,360	7,275 / 3,300
10738399-350	5.1/2 x 350 PSL2	350	1,500 / 1,360	10,610 / 4,812
10730284-350	5.1/2 x 350 PSL1	350	1,500 / 1,360	10,610 / 4,812
10730284-480	5.1/2 x 480 PSL1	480	1,500 / 1,360	14,450 / 6,554
10738399-480	5.1/2 x 480 PSL2	480	1,500 / 1,360	14,450 / 6,554
10738399-600	5.1/2 x 600 PSL2	600	1,500 / 1,360	18,190 / 8,250
10730284-600	5.1/2 x 600 PSL1	600	1,500 / 1,360	18,190 / 8,250

\* Other lengths available on request.

## PERFECTION LINKS

Dependable, efficient Perfection links are designed for light loads. They are made by forging, bending and electric welding of high-quality steel bar stock, which is then heat-treated and magnafluxed.

For loads which exceed capacity of Perfection links, Weldless links are recommended.

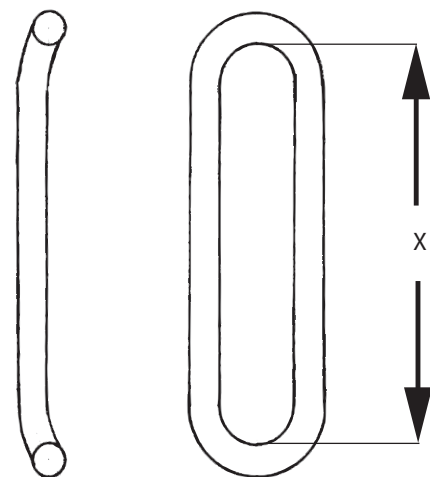

## PART NUMBERS PERFECTION LINKS

Part number	Size [inches/mm]	Load rating per set [sTon/Tonne]	Weight per Set [lbs/kg]	Dimension X [inches/mm]
200450Y130	2 x 30 / 50.8 x 762	100 / 89.3	49 / 108	30 / 762
200450Y136	2 x 36 / 50.8 x 914	100 / 89.3	58 / 128	36 / 914
200450Y142	2 x 42 / 50.8 x 1,067	100 / 89.3	67 / 148	42 / 1,067
200450Y148	2 x 48 / 50.8 x 1,219	100 / 89.3	76 / 168	48 / 1,219
200450Y160	2 x 60 / 50.8 x 1,524	100 / 89.3	95 / 208	60 / 1,524

## DC DOLLY

Efficient method of handling drill collars without having to remove the elevator from the links. The drill collar assemblies are suitable for use in combination with the perfection links. The size range is from 2.7/8" plain to 6.5/8" IEU.

### PART NUMBERS DC DOLLIES

Part number	Size [inches]	Load rating [sTon/Tonne]	Weight [lbs/kg]
<b>18° type</b>			
31189Y1	4.1/2" IF & 5" IEU	150 / 136	87 / 192
31189Y7	3.1/2" IF, Reg & FH	150 / 136	83.5 / 184.1
31189Y10	5.1/2" IEU -18	150 / 136	209 / 94.8
31189Y18	5.7/8" IEU -18	150 / 136	252.7 / 114.6
<b>Collar type</b>			
31189Y3	4.1/2" IF & 5" IEU	150 / 136	204.2 / 92.6
31189Y5	4" IF & 4.1/2" Reg & FH	150 / 136	198.3 / 89.9
31189Y9	4 FH	150 / 136	181.1 / 82.1
31189Y12	3.1/2" IF & 5" IEU	150 / 136	191.7 / 87
31189Y15	6.5/8" EU	150 / 136	253.5 / 115
31189Y16	2.7/8" Plain	150 / 136	253.5 / 115





# ELEVATOR SELECTION CHARTS

## ELEVATOR/PIPE MATCHING TOOL

A high percentage of all dropped pipe incidents is related to selecting the wrong pipe size and/or elevator bore size.

To reduce this specific risk, NOV has developed a measuring tool that allows easy, fast and precise measurement of pipe body OD & the tool joint OD versus the elevator bore ID & the tool joint bore ID, up to 9" (229 mm).



### ID MEASUREMENT:

1. Insert "BoreMatch" tool into bore.
2. Spread the "BoreMatch" tool legs until the two outer tips with arrow marking make contact to bore.
3. Gently remove the "BoreMatch" tool from the bore and read the "ID".

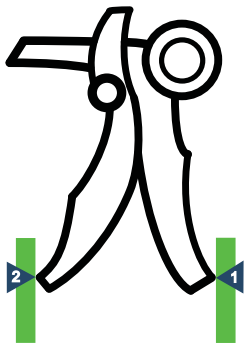

### MATCHING PIPE example:



Measure elevator bore (ID) with 2-point measurement. Readout 6.1/8".

### MATCHING TOOL JOINT example:



Measure elevator T-J-Bore (ID) with 2-point measurement. Readout 8.1/4".

### OD MEASUREMENT:

1. Extend the "BoreMatch" tool around the pipe.
2. Push the "BoreMatch" tool against the pipe until the two legs and the center tip with arrow marking make contact with the pipe.
3. Gently remove the "BoreMatch" tool from the pipe and read the "OD".

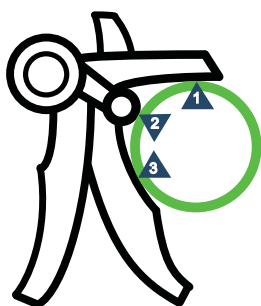

Measure pipe body (OD) with 3-point measurement. Readout 6".  
The pipe matches with the bore.



Measure pipe T-J-Diameter (OD) with 3-point measurement. Readout 8".  
The tool joint matches with the bore.

### FEATURES AND BENEFITS:

- Proper elevator selection with specific pipe, as a result reduced risk of dropped pipe incidents
- Not sensitive to dirt (i.e. mud)
- Wear indicator for reliable measurement
- Accuracy up to 1/16 inch or 1.5mm
- Light weight — plastic components eliminate the risk of down time when dropped in hole
- Graphics recessed and applied by laser to minimize risk contrast loss
- Contrasting surface roughness to ease dimension reading
- Part Number: 10710179-001

## ELEVATOR SELECTION CHARTS

SLIP TYPE ELEVATORS Y SERIES										
Size	Size	Type	Part number	Cap.	Max. Weight	Max. Weight	Link size (min / max)			
[inches]	[mm]			[sTon]	[lbs]	[kg]	[inches]	[mm]	[inches]	[mm]
1.315" - 2.7/8"	33-73	MYT	29328Y	40	148	67	1.1/4"	32	2.3/4"	70
1.315" - 3.1/2"	33-89	YT	50006582Y	75	355	161	2.1/4"	57	2.3/4"	70
2.3/8" - 3.1/2"	60-89	HYT	39284Y	150	740	336	2.1/4"	57	3.1/2"	89
3.1/2" - 7"	89-178	YC	24140Y	75	445	206	2.1/4"	57	2.3/4"	70
3.1/2" - 7"	89-178	MYC	200360Y	125	750	336	2.1/4"	57	2.3/4"	70
2.7/8" - 7.3/4"	73-197	HYC	BJ55310Y	200	997	452	2.1/4"	57	3.1/2"	89
2.7/8" - 7.3/4"	73-197	HYC AO	BJ70166Y	200	1465	665	2.1/4"	57	3.1/2"	89
COLLAR TYPE CENTER LATCH ELEVATORS A SERIES										
1.050" - 2.7/8"	28-73	TA	32387Y*	35	57	26	1.1/4"	32	1.3/4"	45
2.3/8" - 5"	60-127	TMA	50006310Y *	100	121	55	1.3/4"	45	2.3/4"	70
4.3/4" - 8.5/8"	121-219	TA	200000Y*	100	260	118	1.3/4"	45	2.3/4"	70
4.1/2" - 8.5/8"	121-219	TA	32754Y*	150	370	168	1.3/4"	45	3.1/2"	89
4.1/2" - 8.5/8"	121-219	TA AO	35636Y*	150	530	240	1.3/4"	45	3.1/2"	89
8.1/2" - 11.1/4"	216-286	TA	39342Y*	150	524	238	1.3/4"	45	3.1/2"	89
8.1/2" - 11.1/4"	216-286	TA AO	39343Y*	150	550	250	1.3/4"	45	3.1/2"	89
2.7/8" - 4.3/4"	70 - 120	RGA	201360Y*	200	304	138	1.3/4"	45	2.3/4"	70
3.1/2" - 7"	89 - 178	GA	200034Y*	350	608	276	2.1/4"	57	3.1/2"	89
3.1/2" - 7"	89 - 178	GAAO	200035Y*	350	725	330	2.1/4"	57	3.1/2"	89
4" - 7.5/8"	102 - 193	GGA	201385Y*	350	693	314	2.1/4"	57	3.1/2"	89
4" - 7.5/8"	102 - 193	GGAAO	201380Y*	350	998	454	2.1/4"	57	3.1/2"	89
18° CENTER LATCH ELEVATOR G SERIES										
2.3/8" - 5"	60-127	MG	30157Y*	100	233	106	1.3/4"	45	2.3/4"	70
2.3/8" - 3.1/2"	60-89	RGG	200680Y*	150	304	138	1.3/4"	45	2.3/4"	70
2.7/8" - 5.1/2"	89-140	MGG	35005Y*	250	608	276	2.1/4"	57	3.1/2"	89
2.7/8" - 5.1/2"	89-140	MGG AO	36056Y*	250	720	327	2.1/4"	57	3.1/2"	89
4" - 5.1/2"	102-140	GG	31068Y*	350	693	314	2.1/4"	57	3.1/2"	89
4" - 5.1/2"	102-140	GG AO	35143Y*	350	1018	463	2.1/4"	57	3.1/2"	89
4" - 6.5/8"	102-168	HGG	70013Y*	500	1029	467	2.1/4"	57	3.1/2"	89
4" - 6.5/8"	102-168	HGG AO	70222Y*	500	1441	654	2.1/4"	57	3.1/2"	89
18° CENTER LATCH ELEVATOR G SERIES (with wear bushing)										
3.1/2" - 5.1/2"	89-140	MGG	200058Y*	250	585	266	2.1/4"	57	3.1/2"	89
3.1/2" - 5.1/2"	89-140	MGG AO	200057Y*	250	720	332	2.1/4"	57	3.1/2"	89
4" - 5.1/2"	102-140	GG	200056Y*	350	680	310	2.1/4"	57	3.1/2"	89
4" - 5.1/2"	102-140	GG AO	200024Y*	350	1010	459	2.1/4"	57	3.1/2"	89
4" - 5.1/2"	102-140	HGG	200060Y*	500	1010	459	2.1/4"	57	3.1/2"	89
4" - 5.1/2"	102-140	HGG AO	200059Y*	500	1510	685	2.1/4"	57	3.1/2"	89
5.1/2" - 6.5/8"	140-168	HGG	200062Y*	500	1010	459	2.1/4"	57	3.1/2"	89
5.1/2" - 6.5/8"	140-168	HGG AO	200061Y*	500	1510	685	2.1/4"	57	3.1/2"	89

\* bore code, see chapter "Elevator bore charts"



### COLLAR TYPE SIDE DOOR ELEVATORS X SERIES

Size [inches]	Size [mm]	Type	Part number	Rated Load [sTon / Tonne]	Max. Weight [lbs]	Max. Weight [kg]	Link size (min / max)			
							[inches]	[mm]	[inches]	[mm]
1.660" - 2.7/8"	42-73	SLX	33734Y*	65 / 59	50	23	1.3/4"	44	2.1/4"	57
2.3/8" - 2.7/8"	60-73	SLX	33693Y*	100 / 91	75	34	1.3/4"	44	2.3/4"	70
3.1/2" - 4"	89-101.6	SLX	33809Y*	100 / 91	114	58	1.3/4"	44	2.3/4"	70
3.1/2" - 5.3/4"	89-146	SMX	50006430Y*	150 / 136	278	126	2.1/4"	57	2.3/4"	70
4.1/2" - 5.1/2"	89-146	SLX	33854Y*	100 / 91	145	66	1.3/4"	44	2.3/4"	70
5.1/2" - 8.5/8"	140-219	SLX	31239Y*	150 / 136	326	148	1.3/4"	44	3.1/2"	89
6" - 9"	152-229	SMX	50006438Y*	150 / 136	291	132	2.1/4"	57	3.1/2"	89
6" - 9"	152-229	SMX	50006426Y*	250 / 227	474	215	2.1/4"	57	3.1/2"	89
9.5/8" - 10.3/4"	245-273	SLX	33950Y*	150 / 136	357	162	1.3/4"	44	3.1/2"	89
9.1/8" - 13.3/8"	231-340	SMX	50006454Y*	150 / 136	406	187	2.1/4"	57	3.1/2"	89
9.1/8" - 13.3/8"	231-340	SMX	50006740Y*	250 / 227	563	255	2.1/4"	57	3.1/2"	89
9.1/8" - 13.3/8"	231-340	SMX	50006440Y*	350 / 318	563	255	2.1/4"	57	3.1/2"	89
9.5/8" - 13.5/8"	245-340	SX	29965Y*	350 / 318	1200	544	2.1/4"	57	3.1/2"	89
9.5/8" - 13.5/8"	245-340	SX	29964Y*	350 / 318	1235	560	2.3/4"	70	3.1/2"	89
11.3/4" - 13.3/8"	289-340	SLX	33982Y*	150 / 136	448	203	1.3/4"	44	3.1/2"	89
13.1/2" - 17.7/8"	343-454	SMX	50006450Y*	250 / 227	679	308	2.1/4"	57	3.1/2"	89
16"	406	SLX	34087Y*	150 / 136	1200	544	1.3/4"	44	3.1/2"	89
16"	406	SX	30729*	350 / 318	1200	544	2.3/4"	70	3.1/2"	89
18" - 24.1/2"	457-622	SMX	50006460Y*	250 / 227	902	409	2.1/4"	57	3.1/2"	89
18.5/8" - 20"	473-508	SLX	33632Y*	150 / 136	705	320	1.3/4"	44	3.1/2"	89
24.1/2"	622	SLX	34175Y*	250 / 227	1208	548	1.3/4"	44	3.1/2"	89
26" - 30"	663-762	SLX DD	52755Y*	150 / 136	1820	826	1.3/4"	44	3.1/2"	89

### AUXILIARY ELEVATORS S SERIES

2.3/8" - 3.1/2"	60-89	SJL	70499*	5 / 4.5	45	20
4" - 5.1/2"	102-140	SJL	70500Y*	5 / 4.5	51	23
6" - 7.5/8"	152-194	SJL	70501Y*	5 / 4.5	72	32
8.5/8" - 10.3/4"	219-273	SJL	70502Y*	5 / 4.5	98	44
11.3/4" - 14"	298-340	SJL	70503Y*	5 / 4.5	121	55
16" - 20"	406-508	SJL	70504Y*	5 / 4.5	233	105
21" - 24.1/2"	546-622	SJL	70505Y*	5 / 4.5	283	128
2.7/8" - 5.1/2"	73-127	SPL 5°	200008Y*	5 / 4.5	77	35
5.1/2" - 7.5/8"	140-194	SPL 5°	200010Y*	5 / 4.5	108	49
8.5/8" - 9.5/8"	219-244	SPL 5°	200012Y*	5 / 4.5	145	66
10.3/4"	273	SPL 5°	200013Y*	5 / 4.5	160	73
2.3/8" - 4.1/2"	60-114	SPL 12°	200014Y*	5 / 4.5	86	39
2.3/8" - 5"	60-127	SPL 18°	200009Y*	5 / 4.5	79	36
5.1/2" - 6.5/8"	140-168	SPL 18°	200011Y*	5 / 4.5	94	42

### DOUBLE HINGED SINGLE JOINT ELEVATORS SJX SERIES

2.3/8" - 4.1/2"	60-114	SJX	50004929Y*	5 / 4.5	37	17
4.1/2" - 7"	114-178	SJX	50004931Y*	5 / 4.5	44	20
7" - 10"	178-254	SJX	50004933Y*	5 / 4.5	57	25
10" - 14"	254-356	SJX	50004935Y*	5 / 4.5	67	30

### SJH HORIZONTAL PICK UP ELEVATORS SERIES

Size [inches]	P/n Frame	Pipe type	P/n Jaws	Rated Load [sTon / Tonne]	Max. Weight [kg]	Max. Weight [kg]
2.3/8" - 4.1/2"	50003135	Tbg / Dp	50003148Y*	5 / 4.5	100	45
4.1/2" - 7.5/8"	50003155	Tbg / Dp	50003189Y*	5 / 4.5	111	50.5
7" - 10.3/4"	50003175	Csg	50003150Y*	5 / 4.5	132	60

\* bore code, see chapter "Elevator bore charts"

# ELEVATOR BORE CHARTS

## HOW TO USE THE BORE CHARTS

When ordering any elevator for drill pipe, casing and tubing, first determine correct pipe size and corresponding elevator part number from specification tables on these pages. Then determine correct bore code from bore charts on this and the following pages. Add this number to the part number for the complete elevator.

Note that the bore diagrams give bore diagrams for all elevators other than BJ 18° elevators.

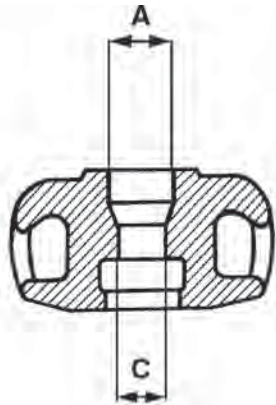

18° Taper Elevator

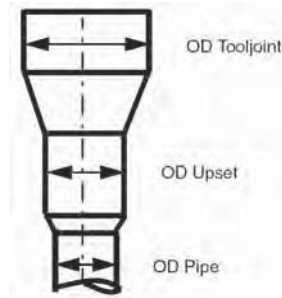

Drill Pipe

## DRILL PIPE BORE CODES

Drill pipe size Max OD	Type Upset	Upset Max OD	Elevator Dimension Center bore C (new)	Dimension Top bore A (new)	Bore code 18° taper	Standard Connection	Hydril Wedge* Thread	Grant Prideco
2.3/8"	EU	2.9/16"	2.21/32"	4.1/4"	116	OH NC 26 (IF) SL H90 WO	WT 14S, 23, 26	XT 24, 26 HT 26 GPDS 26
2.7/8"	EU	3.3/16"	3.9/32"	4.3/4"	118	NC 31(IF) OH SL H90 WO	WT 14S, 31	XT 31 HT 31 GPDS 31
3.1/2"	IU	3.11/16"	3.25/32"	5.1/2"	119	XH NC 31(SH)	WT 14S, 31	XT 31 HT 31
3.1/2"	EU	3.7/8"	3.31/32"	5.1/2"	120	NC 38(IF) OH SL H90 WO	WT 31, 38	XT 38 HT 38 GPDS 38
4"	IU	4.3/16"	4.9/32"	6.1/2"	121	NC 40(FH) SH H90	WT 31, 38, 39	XT 38, 39 HT 38, 40 GPDS 40
4"	EU	4.1/2"	4.25/32"	6.3/4"	122	NC 46(IF) OH WO	WT 40	
4.1/2"	IU	4.11/16"	4.25/32"	6.3/4"	122	H90	WT 38	
4.1/2"	IEU	4.11/16"	4.25/32"	6.3/4"	122	NC 46(XH) FH NC 38(SH) H90	WT 39, 40	XT 40, 46 HT 46 GPDS 46
4.1/2"	EU	5" - 5.1/8"	5.1/4"	7.1/8"	123	NC 50(IF) OH WO	WT 46	XT 50 HT 50
5"	IEU	5.1/8"	5.1/4"	7.1/8"	123	NC 50(XH)	WT 39, 40, 46, 50	XT 46, 50 HT 50 GPDS 50
5"	IEU	5.1/8"	5.1/4"	7.1/2"	756	5.1/2" FH		
5.1/2"	IEU	5.11/16"	5.13/16"	7.7/8"	124	FH	WT 46, 50, 54, 56	XT 54, 57 HT 55 GPDS 55
5.1/2"	EIU		6.233"	8"	678	IF	Mannesmann	
5.1/2"	IEU	6"	6.1/8"	8.1/4"	770		WT 54, 56	XT 57
5.7/8"	IEU	6"	6.1/8"	8.1/4"	789			XR
6.5/8"	IEU	6.3/4"	5.11/16"	8.7/8"	740	FH	WT 56, 66	XT 65 HT 65 GPDS 65

\*HYDRIL and WEDGE are trademarks of Hydril Company. The Hydril trademarks and trade names referenced above are used solely for reference purposes and NOV is not affiliated with Hydril and Hydril does not endorse any of NOV's products.\*

## DRILL COLLARS WITH ZIP LIFT RECESS BORE CHART

Drill collar OD	ZIP OD	Bore code	Top bore A	Bevel C	Bottom bore B
4.1/8"	3.11/16"	177	3.13/16"	1/16"	4.1/4"
4.3/4"	4.1/4"	435	4.3/8"	1/16"	4.7/8"
5.1/4"	4.3/4"	179	4.7/8"	1/16"	5.3/8"
5.1/2"	5"	180	5.1/8"	1/16"	5.5/8"
5.3/4"	5.1/8"	181	5.1/4"	1/16"	5.7/8"
6"	5.3/8"	362	5.1/2"	1/16"	6.1/8"
6.1/4"	5.5/8"	337	5.3/4"	1/16"	6.3/8"
6.1/2"	5.7/8"	373	6"	1/16"	6.5/8"
6.3/4"	6"	387	6.3/16"	3/32"	6.7/8"
7"	6.1/4"	361	6.7/16"	3/32"	7.1/8"
7.1/4"	6.1/2"	357	6.11/16"	3/32"	7.3/8"
7.1/2"	6.3/4"	188	6.15/16"	3/32"	7.5/8"
7.3/4"	7"	339	7.3/16"	3/32"	7.7/8"
8"	7.1/4"	336	7.7/16"	3/32"	8.1/8"
8.1/4"	7.1/2"	422	7.11/16"	3/32"	8.3/8"
8.1/2"	7.3/4"	426	7.15/16"	3/32"	8.5/8"
9"	8.1/8"	427	8.3/8"	1/8"	9.1/8"
9.1/2"	8.5/8"	370	8.7/8"	1/8"	9.5/8"
9.3/4"	8.7/8"	367	9.1/8"	1/8"	9.7/8"
10"	9.1/8"	195	9.3/8"	1/8"	10.1/8"
10.3/4"	9.7/8"	527	10.1/8"	3/32"	10.7/8"
11"	10.1/8"	419	10.3/8"	1/8"	11.1/8"
11.1/4"	10.3/8"	196	10.5/8"	1/8"	11.3/8"

## PLAIN DRILL COLLARS WITH LIFT PLUGS BORE CHART

Drill collar OD	Bore code	Top bore A	Bevel C	Bottom bore B
2.1/2"	201	2.21/32"	1/16"	2.21/32"
2.3/4"	203	2.29/32"	1/16"	2.29/32"
3"	205	3.5/32"	1/16"	3.5/32"
3.1/8"	206	3.9/32"	1/16"	3.9/32"
3.1/4"	207	3.13/32"	1/16"	3.13/32"
3.1/2"	209	3.21/32"	1/16"	3.21/32"
3.3/4"	211	3.29/32"	1/16"	3.29/32"
4"	213	4.5/32"	1/16"	4.5/32"
4.1/8"	519	4.9/32"	1/16"	4.9/32"
4.1/4"	548	4.13/32"	1/16"	4.13/32"
4.1/2"	215	4.21/32"	1/16"	4.21/32"
4.3/4"	354	4.15/16"	1/16"	4.15/16"
5"	552	5.3/16"	1/16"	5.3/16"
5.1/4"	219	5.7/16"	1/16"	5.7/16"
5.1/2"	411	5.11/16"	1/16"	5.11/16"
5.3/4"	222	5.31/32"	1/16"	5.31/32"
6"	349	6.7/32"	1/16"	6.7/32"
6.1/4"	348	6.15/32"	1/16"	6.15/32"
6.3/8"	331	6.19/32"	1/16"	6.19/32"
6.1/2"	765	6.23/32"	1/16"	6.23/32"
6.3/4"	338	7"	1/16"	7"
7"	372	7.1/4"	1/16"	7.1/4"
7.1/4"	335	7.1/2"	1/16"	7.1/2"
7.1/2"	137	7.3/4"	1/16"	7.3/4"
7"	550	8"	1/16"	8"
8"	334	8.1/4"	1/16"	8.1/4"
8.1/4"	347	8.1/2"	1/16"	8.1/2"
8.1/2"	580	8.25/32"	1/16"	8.25/32"
8.3/4"	226	9.1/32"	1/16"	9.1/32"
9"	356	9.9/32"	1/16"	9.9/32"
9.1/4"	227	9.17/32"	1/16"	9.17/32"
9.1/2"	346	9.25/32"	1/16"	9.25/32"
10"	228	10.11/32"	1/16"	10.11/32"
10.1/2"	229	10.27/32"	1/16"	10.27/32"
11"	230	11.11/32"	1/16"	11.11/32"

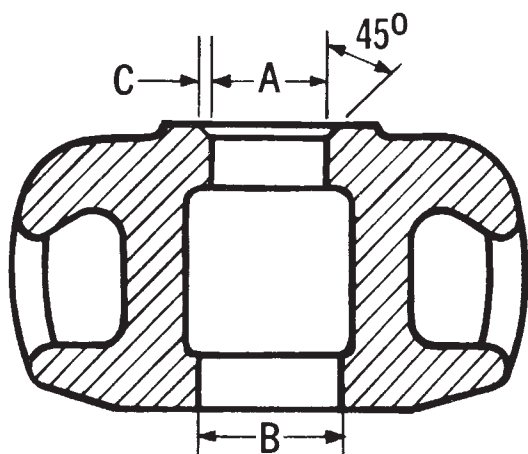

## TUBING BORE CHART

Tubing size	Style	Bore code	Top bore A	Bottom bore B
1.050"	Plain	150	1.125"	1.125"
	Upset Tubing	151	1.422"	1.422"
1.315"	Plain	152	1.390"	1.390"
	Upset Tubing	153	1.578"	1.578"
1.660"	Plain	154	1.734"	1.734"
	Upset Tubing	155	1.922"	1.922"
1.900"	Plain	156	1.984"	1.984"
	Upset Tubing	157	2.203"	2.203"
2.3/8"	Plain	158	2.453"	2.453"
	Upset Tubing	159	2.703"	2.703"
2.7/8"	Plain	160	2.953"	2.953"
	Upset Tubing	161	3.203"	3.203"
3.1/2"	Plain	162	3.578"	3.578"
	Upset Tubing	163	3.859"	3.859"
4"	Plain	164	4.078"	4.078"
	Upset Tubing	165	4.359"	4.359"
4.1/2"	Plain	129	4.594"	4.594"
	Upset Tubing	167	4.859"	4.859"

## COLLAR TYPE DRILL PIPE BORE CHART

Bore Code	Top Bore A	Bottom Bore B
101	3.3/8"	3.1/8"
102	3.13/16"	3.3/4"
103	4.1/16"	3.3/4"
104	4.5/16"	4.1/4"
105	4.13/16"	4.3/4"
106	5.5/16"	5.1/4"
107	5 7/8"	5.13/16"
108	3.1/8"	3.1/8"
109	2.5/8"	2.5/8"
110	2.3/4"	2.3/4"
111	3.1/2"	3.1/2"
112	3.1/16"	3.1/16"
113	5.11/16"	5.11/16"
114	6.1/4"	6.1/4"
115	2.13/16"	2.13/16"

## CASING BORE CHART

Casing size	Bore code	Top bore A	Bottom bore B
4.1/2"	129	4.19/32"	4.19/32"
4.3/4"	130	4.27/32"	4.27/32"
5"	131	5.1/8"	5.3/32"
5.1/2"	132	5.5/8"	5.5/8"
5.3/4"	133	5.7/8"	5.7/8"
6"	134	6.1/8"	6.1/8"
6.5/8"	135	6.3/4"	6.3/4"
7"	136	7.1/8"	7.1/8"
7.5/8"	137	7.3/4"	7.3/4"
8.5/8"	139	8.25/32"	8.25/32"
9"	140	9.5/32"	9.5/32"
9.5/8"	141	9.25/32"	9.25/32"
9.7/8"	649	10.1/8"	10.1/8"
10"	831	10.156"	10.156"
10.1/8"	846	10.3"	10.3"
10.3/4"	142	10.15/16"	10.29/32"
11.3/4"	143	11.15/16"	11.15/16"
13.3/8"	144	13.9/16"	13.9/16"
13.5/8"	596	13.13/16"	13.13/16"
14"	690	14.13/64"	14.13/64"
16"	145	16.7/32"	16.7/32"
18"	723	18.1/4"	18.1/4"
18.5/8"	146	18.7/8"	18.7/8"
20"	147	20.9/32"	20.1/4"
21.1/2"	148	21.25/32"	21.25/32"
22"	688	22.9/32"	22.9/32"
24"	630	24.5/16"	24.5/16"
24.1/2"	149	24.13/16"	24.13/16"
26"	650	26.11/32"	26.11/32"
28"	693	28.23/64"	28.23/64"
30"	644	30.3/8"	30.3/8"

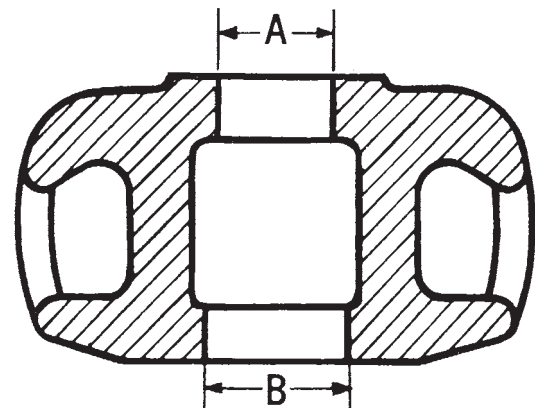



# MANUAL & AIR OPERATED ELEVATORS



## MANUAL OPERATED ELEVATORS

Manual operated elevators are conventionally operated elevators for lifting all existing pipe:

- Collar type center latch A series
- 18° center latch G series
- Collar type side door X series
- Auxiliary S-series

The elevators are suitable for handling casing, tubing, plain & upset drill pipe, collar type drill pipe, 18° drill pipe, IU, EU and IEU pipe etc, depending on the type and rating.



## AIR OPERATED ELEVATORS

Air operated elevators are conventional center latch elevators to which power actuation has been added. This feature permits remote opening of the elevators. All NOV elevators are designed and manufactured in strict accordance with ISO-API standard 8C.



## SLIP TYPE ELEVATORS

NOV "Y" series elevators are conventional slip type elevators for handling tubing and small casing. They feature a four slip design which give an optimum contact on the pipe to prevent bottle necking and gauge damage.

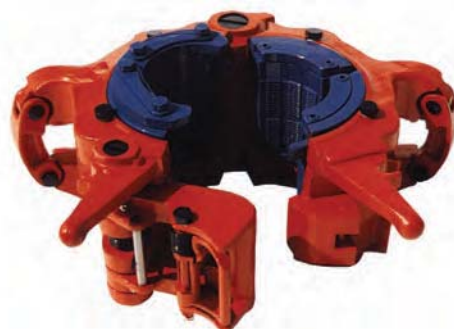

## SLIP TYPE ELEVATORS MYC, YC & HYC SERIES

### HYC Casing Elevator

The HYC elevator is a powerful 200 sTon (181 Tonne) capacity elevator and can handle from 2.7/8" to 7.3/4" tubing or casing. The full range can be achieved with the use of 5 sets of slips for the complete range. All slips provide a full 10.1/2" (7.5/8" slip has a height of 8.625") of insert contact to firmly grip your casing or tubing. The HYC elevator as with all Type "Y" series elevators operate with the latch lock combination for safety.

Size range and capacity:

2.7/8" through 7.3/4" (73-197 mm) OD. API rated capacity is 200 sTon (181 Tonne).

### MYC Casing Elevator

With its 125 sTon (114 Tonne) capacity the MYC elevator completes the range of Y type elevators for handling either external upset or API collar type casing or tubing. The MYC elevator has a range of 3.1/2" to 7", utilizing the same slips as the YC elevator. All slips provide a full 7" of insert contact to firmly grip your casing or tubing. The MYC operates with a latch and a latch lock combination for safety.

Size range and capacity:

3.1/2" to 7" (89-178mm) OD. API rated capacity is 125 sTon (114 Tonne).

### YC Casing Elevator

The YC elevator is an exceptionally versatile elevator that handles either external upset or API collartype casing simply by installing the proper size insert-type slips and slip-setting ring assembly. In addition, slips can be provided that enable the YC elevator to handle dual strings of tubing. To reduce the possibility of the elevator opening under load, a latch lock is provided in addition to the spring type-latch. The rugged, long-lasting slip inserts are easily changed when they become worn.

Size range and capacity:

3.1/2" (89 mm) through 7" (178 mm) casing. API rated capacity is 75 sTon (68 Tonne)

## TECHNICAL SPECIFICATIONS

Type	Part number	Load rating [sTon]	Size		Max. Weight		Link size (min / max)			
			[inches]	[mm]	[lbs]	[kg]	[inches]	[mm]	[inches]	[mm]
YC	24140Y	75	3.1/2 - 7	89-178	445	206	2.1/4	57	2.3/4	70
MYC	200360Y	125	3.1/2 - 7	89-178	750	336	2.1/4	57	2.3/4	70
HYC	BJ55310Y	200	2.7/8 - 7.3/4	73-197	997	452	2.1/4	57	3.1/2	89
HYC AO * SR4	BJ70166Y	200	2.7/8 - 7.3/4	73-197	1415	642	2.1/4	57	3.1/2	89

## SLIP ASSEMBLIES

HYC									
Size	Slip assembly part number	Slip setting ring part number	Insert part number	No. required	Bottom guide plate set part number	Weight Slip Ass'y		Weight Guide plate	
						[lbs]	[kg]	[lbs]	[kg]
3.1/2"	201353Y	55516	16441	24	26827-1	282	128	18	8
3.1/2" x 2.7/8" *	201355Y	201357	201356	24	201358	282	128	18	8
4.1/2" x 3.1/2"	55509Y	55516	24779	24	26827-1	275	125	15	7
4.1/2" x 4"	55510Y	55517	24781	24	26827	270	123	15	7
4.1/2"	55511Y	55518	BJ16408	24	24071-4	268	122	5	2
5.1/2" x 4.1/2"	55513Y1	55518	24785	36	24071-4	268	122	5	2
5.1/2" x 5"	55512Y	55520	24783	36	24071	251	114	14	6
5.1/2"	55513Y	55520	BJ16407	36	24071-1	238	108	13	6
7" x 5.3/4"	55515Y2	55520-1	29254	48	24071-7	238	108	13	6
7" x 6"	55515Y1	55520-1	24785	48	24071-5	234	106	10	5
7" x 6.5/8"	55514Y	55521	24748	48	24071-3	234	106	10	5
7"	55515Y	55522	BJ16407	48	24071-2	229	104	8	4
7.5/8" x 6.5/8"	70009Y2	200217	25474-1	48	24071-3	229	104	8	4
7.5/8" x 7"	70009Y1	200440	26750-1	48	24071-2	229	104	8	4
7.5/8" x 7.1/4"	70009Y5	200440-1	39287-1	48	24071-9	230	105	7	3
7.5/8"	70009Y	70012	70010	48	24071-6	230	105	7	3
7.3/4"	70009Y4	201546	32477-1	48	24071-8	230	105	7	3

MYC & YC									
Size	Slip assembly part number	Slip setting ring part number	Insert part number	No. required	Bottom guide plate set part number	Weight		Weight Guide plate	
						[lbs]	[kg]	[lbs]	[kg]
4.1/2" x 3.1/2"	34931Y	34932	24779	16	26827-1	130	59	15	7
4.1/2" x 4"	26830Y	30209	24781	16	26827	120	54	15	7
4.1/2"	24072Y5	30219	BJ16408	16	24071-4	116	53	5	2
5.1/2" x 5"	24072Y7	30220	24783	16	24071	112	51	14	6
5.1/2"	24072Y2	30223	BJ16407	16	24071-1	101	46	13	6
7" x 6.5/8"	24077Y7	30226	24748	24	24071-3	97	44	10	5
7"	24077Y1	30229	BJ16407	24	24071-2	95	43	8	4

\* Requires special trigger part number 203333

## SLIP TYPE ELEVATORS YT, MYT & HYT SERIES

### YT Slip Tubing Elevator

The YT elevator is an outstanding combination tool for use with any of the power tubing spiders. It has four slips each contacting 9' (228.6 mm) of pipe length. The interlocking slips form a circle around the tubing, assuring a uniform grip. Slip inserts are easily replaceable. Only one set of slip bodies is required to handle all tubing sizes from 1.315" (33 mm) through 3.1/2" (89 mm). A sturdy latch and safety latch lock combination holds the YT elevator securely in closed position.

### HYT Tubing Elevator

The HYT elevator is designed to accommodate the widest possible range of tubing. The key is the various combinations possible with three different slip-setting rings, reducing inserts and two sizes of slips. The HYT elevator handles 2.3/8", 2.7/8" or 3.1/2" (60.33, 70.02 or 88.9 mm) OD tubing, with any type of upset and any wall thickness. The slip provides a full 12" (304.8 mm) of vertical contact on the pipe.

### MYT Slip Tubing Elevator

The MYT elevator is a light-weight elevator for medium wells. It handles all tubing within its range with one set of slips, plus reducing inserts. The MYT elevator has four curved slips that form a circle around the tubing. This assures an uniform grip with minimum marking of pipe.



## TECHNICAL SPECIFICATIONS

Type	Part number	Load Rating [sTon]	Size		Max. Weight		Link Size Min/Max			
			[inches]	[mm]	[lbs]	[kg]	[inches]	[mm]	[inches]	[mm]
YT	50005682Y	75	1.315" - 3.1/2"	33-89	355	161	2.1/4"	57	2.3/4"	70
HYT	39284Y	150	2.3/8" - 3.1/2"	60-89	740	336	2.1/4"	57	3.1/2"	89
MYT	29328Y	40	1.315" - 2.7/8"	33-73	148	67	1.1/4"	32	2.3/4"	70

## SLIP ASSEMBLIES

YT				
Nominal x Pipe Size	Slip assembly part number	Slip setting ring part number	Insert part number	No. required
2.7/8"	23108Y4	27695	24773	12
2.7/8" x 2.3/8"	23108Y6	27694	29255	12
2.7/8" x 2.1/16"	23108Y7	27812	29256	12
2.7/8" x 2"	23108Y8	27821	29256	12
2.7/8" x 1.900"	23108Y9	27811	29257	12
2.7/8" x 1.600"	23108Y10	27810	29258	12
2.7/8" x 1.315"	23108Y11	29001	29259	12
3.1/2"	23108Y5	27813	24774	24
3.1/2" x 2.7/8"	23108Y3	27695	30358	24
HYT				
Nominal x Pipe Size	Slip assembly part number	Slip setting ring part number	Insert part number	No. required
2.7/8"	39259Y2	39214-2	24773	16
2.7/8" x 2.3/8"	39259Y4	39214-1	29255	16
3.1/2"	39258Y2	39214-3	24774	32
3.1/2" x 2.7/8"	39258Y4	39214-2	30358	32
MYT				
Nominal x Pipe Size	Slip assembly part number	Slip setting ring part number	Insert part number	No. required
2.1/16"	29343Y3	29350	29256	8
2.1/16" x 2"	29343Y4	29351	29256	8
2.1/16" x 1.900"	29343Y5	29352	29257	8
2.1/16" x 1.660"	29343Y6	29353	29258	8
2.1/16" x 1.315"	29343Y7	29354	29259	8
2.7/8"	29343Y1	29348	24773	8
2.7/8" x 2.3/8"	29343Y2	29345	29255	8

## COLLAR TYPE ELEVATORS A SERIES

### COLLAR TYPE ELEVATORS A SERIES

Center-latch elevators are for handling collar-type drill pipe, casing and tubing. All "A" type elevators are constructed in two halves of practically the same weight, providing proper balance and easier opening and closing. In open position, the elevator hangs ready for closing at any point below the upset of the pipe. All "A" type elevators feature latch and safety latch lock combinations. Safety features include operating handles to help prevent accidents to operators and an extra handle at the rear of the elevator for safer operation.



### TECHNICAL SPECIFICATIONS A SERIES

Type	Part number*	Size	Size	Load Rating	Max. Weight		Link Size			
		[inches]	[mm]		[sTon]	[lbs]	[kg]	[inches] Min	[mm] Min	[inches] Max
TA	32387Y	1.050" - 2.7/8"	28-73	35	57	26	1.1/4"	32	1.3/4"	44
TMA	50006310Y	2.3/8" - 5"	60-127	100	121	55	1.3/4"	44	2.3/4"	70
RGA	201360Y	2.7/8" - 4.3/4"	70 - 120	200	304	138	1.3/4"	44	2.3/4"	70
GA	200034Y	3.1/2" - 7"	89 - 178	350	608	276	2.1/4"	57	3.1/2"	89
GAAO	200035Y	3.1/2" - 7"	89 - 178	350	725	330	2.1/4"	57	3.1/2"	89
GGA	201385Y	4" - 7.5/8"	102 - 193	350	693	314	2.1/4"	57	3.1/2"	89
GGAAO	201380Y	4" - 7.5/8"	102 - 193	350	998	454	2.1/4"	57	3.1/2"	89
TA	200000Y	4.3/4" - 8.5/8"	121-219	100	260	118	1.3/4"	44	2.3/4"	70
TA AO	35636Y	4.1/2" - 8.5/8"	121-219	150	530	240	1.3/4"	44	2.3/4"	70
TA	32754Y	4.1/2" - 8.5/8"	121-219	150	370	168	1.3/4"	44	3.1/2"	89
TA	39342Y	8.1/2" - 11.1/4"	216-286	150	524	238	1.3/4"	44	3.1/2"	89
TA AO	39343Y	8.1/2" - 11.1/4"	216-286	150	550	249	1.3/4"	44	3.1/2"	89

\*See bore code charts

## 18° TYPE ELEVATORS G SERIES

G series elevators are constructed in two halves of practically the same weight for better balance, making them easier to handle; easier to latch on and take off the pipe. In open position, a G series elevator hangs ready for closing at any point below the upset of the pipe. Safety features include guarded operating handles to help prevent accidents to operators and an extra handle at the rear of the elevator for easier, safer operation.



GG series elevator

### TECHNICAL SPECIFICATIONS G SERIES

Type	Part number*	Size [inches]	Size [mm]	Load Rating [sTon]	Max. Weight [lbs]	[kg]	Link Size [inches] Min	[mm] Min	[inches] Max	[mm] Max
MG	30157Y	2.3/8" - 5"	60 - 127	100	233	106	1.3/4"	44	2.3/4"	70
RGG	200680Y	2.3/8" - 3.1/2"	60 - 89	150	304	138	1.3/4"	44	2.3/4"	70
MGG	35005Y	2.7/8" - 5.1/2"	89 - 140	250	608	276	2.1/4"	57	3.1/2"	89
MGG AO	36056Y	2.7/8" - 5.1/2"	89 - 140	250	720	327	2.1/4"	57	3.1/2"	89
GG	31068Y	4" - 5.1/2"	102 - 140	350	693	314	2.1/4"	57	3.1/2"	89
GG AO	35143Y	4" - 5.1/2"	102 - 140	350	720	327	2.1/4"	57	3.1/2"	89
HGG	70013Y	4" - 6.5/8"	102 - 168	500	1029	467	2.1/4"	57	3.1/2"	89
HGG AO	70222Y	4" - 6.5/8"	102 - 168	500	1441	654	2.1/4"	57	3.1/2"	89

\*See bore code charts

### TECHNICAL SPECIFICATIONS G SERIES WITH WEAR BUSHING

Type	Part number *	Size [inches]	Size [mm]	Load Rating [sTon]	Max. Weight [lbs]	[kg]	Link Size [inches] Min	[mm] Min	[inches] Max	[mm] Max
MGG	200058Y	2.7/8" - 5.1/2"	89-140	250	585	266	2.1/4"	57	3.1/2"	89
MGG AO	200057Y	2.7/8" - 5.1/2"	89-140	250	730	332	2.1/4"	57	3.1/2"	89
GG	200056Y	4" - 5.1/2"	102-140	350	680	310	2.1/4"	57	3.1/2"	89
GG AO	200024Y	4" - 5.1/2"	102-140	350	1010	459	2.1/4"	57	3.1/2"	89
HGG	200060Y	4" - 5.1/2"	102-140	500	1010	459	2.1/4"	57	3.1/2"	89
HGG AO	200059Y	4" - 5.1/2"	102-140	500	1510	685	2.1/4"	57	3.1/2"	89
HGG	200062Y	5.1/2" - 6.5/8"	140-168	500	1010	459	2.1/4"	57	3.1/2"	89
HGG AO	200061Y	5.1/2" - 6.5/8"	140-168	500	1510	685	2.1/4"	57	3.1/2"	89

\*See bore code charts

### OPTIONAL EQUIPMENT PART NUMBERS

Part number	Description
15320	Balancing strap for center latch elevators

## X SERIES SIDE DOOR ELEVATORS

The X-series elevators handle all sizes of collar-type tubing, drill pipe and casing. The SMX has a patented latch & latch lock arrangement mounted on the elevator door. The handle protects the latch from accidental opening. Both latches operate from a single handle. The SLX-elevators are offered alternatively to the SMX-elevators. They provide proven technology and economics. The SX-elevator is a mid-sized elevator with higher rating compared to the SLX and SMX, while the SLX DD elevator provides for the largest sizes.



SMX elevator



SLX elevator

### TECHNICAL SPECIFICATIONS X SERIES

Part number	Load Rating [sTon/Tonne]	Size [inches]	Max. Weight		Link size			
			[lbs]	[kg]	[inches] Min	[mm] Min	[inches] Max	[mm] Max
<b>SLX</b>								
33734Y	65 / 59	1.660 - 2.7/8	50	23	1.3/4	44	2.1/4	57
33693Y	100 / 90	2.3/8 - 2.7/8	77	35	1.3/4	44	2.3/4	70
33809Y	100 / 90	3.1/2 - 4	114	58	1.3/4	44	2.3/4	70
33854Y	100 / 90	4.1/2 - 5.1/2	145	66	1.3/4	44	2.3/4	70
31239Y	150 / 136	5.1/2 - 8.5/8	326	148	1.3/4	44	3.1/2	89
33950Y	150 / 136	9.5/8 - 10.3/4	357	162	1.3/4	44	3.1/2	89
33982Y	150 / 136	11.3/4 - 13.3/8	448	203	1.3/4	44	3.1/2	89
34087Y	150 / 136	16	537	244	1.3/4	44	3.1/2	89
33632Y	150 / 136	18.5/8 - 20	705	320	1.3/4	44	3.1/2	89
34175Y	250 / 227	24.1/2	1208	548	1.3/4	44	3.1/2	89
<b>SMX</b>								
50006430Y	150 / 136	3.1/2 - 5.3/4	278	126	2.1/4	57	2.3/4	70
50006438Y	150 / 136	6 - 9	291	132	2.1/4	57	3.1/2	89
50006454Y	150 / 136	9.1/8 - 13.3/8	406	187	2.1/4	57	3.1/2	89
50006426Y	250 / 227	6 - 9	474	215	2.1/4	57	3.1/2	89
50006740Y	250 / 227	9.1/8 - 13.3/8	563	255	2.1/4	57	3.1/2	89
50006440Y	350 / 317	9.1/8 - 13.3/8	563	255	2.1/4	57	3.1/2	89
50006450Y	250 / 227	13.1/2 - 17.7/8	679	308	2.1/4	57	3.1/2	89
50006460Y	250 / 227	18 - 24.1/2	902	409	2.1/4	57	3.1/2	89
<b>SX</b>								
29965Y	350	13.5/8 - 13.3/8	1,200	544	2.1/4	57	3.1/2	89
29964Y	350	9.5/8 - 13.5/8	1,235	560	2.3/4	70	3.1/2	89
30729Y	350	16	1,200	544	2.3/4	70	3.1/2	89
30598Y	350	18.5/8" - 20"	1,400	635	2.3/4	70	3.1/2	89
<b>SLX DD</b>								
52755Y	150	24 - 30	1,820	826	1.3/4	44	3.1/2	89
30598Y		18.5/8 - 20"	1,700	771	1.3/4	44	3.1/2	89

#### Link handle kit

The Link handle kit can be used in combination with a SMX or other kind of Manual Elevator side-door type. It is developed for easier and safer closing the elevator. Part number 50006435. Will fit on 350 and 250 ton links.



## SJL & SPL SERIES ELEVATORS

SJL and SPL single-joint, center-latch elevators are designed to replace unsafe rope slings for hoisting collar-type pipe into position. The SJL 90° elevator enables the crew to handle pipe properly, help avoid damage to pipe threads and reduce the chances of accident or injury. The SPL elevator is the same as the SJL elevator except that the SPL elevator is designed for use on tapered pipe, conforming to API specifications for extreme line casing.



SJL



SPL

### TECHNICAL SPECIFICATIONS SJL SERIES

Type	Part number	Rating [sTon/Tonne]	Size range [Inches]	Max. Weight [lbs]	Max. Weight [kg]
SJL	70499Y*	5 / 4.5	2.3/8 - 3.1/2	45	20
SJL	70500Y*	5 / 4.5	4 - 5.1/2	51	23
SJL	70501Y*	5 / 4.5	6 - 7.5/8	72	32
SJL	70502Y*	5 / 4.5	8.5/8 - 10.3/4	98	44
SJL	70503Y*	5 / 4.5	11.3/4 - 14	121	55
SJL	70504Y*	5 / 4.5	16 - 20	233	105
SJL	70505Y*	5 / 4.5	21 - 24.1/2	283	128

### TECHNICAL SPECIFICATIONS SPL SERIES

Type	Part number	Rating [sTon/Tonne]	Size range [Inches]	Max. Weight [lbs]	Max. Weight [kg]
SPL 5°	200008Y*	5 / 4.5	2.7/8 - 5.1/2	77	35
SPL 5°	200010Y*	5 / 4.5	5.1/2 - 7.5/8	108	49
SPL 5°	200012Y*	5 / 4.5	8.5/8 - 9.5/8	145	66
SPL 5°	200013Y*	5 / 4.5	10.3/4	160	73
SPL 12°	200014Y*	5 / 4.5	2.3/8 - 4.1/2	86	39
SPL 18°	200009Y*	5 / 4.5	2.3/8 - 5	79	36
SPL 18°	200011Y*	5 / 4.5	5.1/2 - 6 5/8	94	42

\*Refer to bore codes

## SIZE COMPONENTS SPL ELEVATORS

Elevator Ass'y No. = Frame No.	Type	Tapered Insert	Qty	Size [inches]	Elevator Ass'y No.	Frame No. Used	Type	Tapered Insert	Qty	Size
200008Y*	SPL 5°	36184-278	6	2.7/8	200014Y*	200008	SPL 12°	53614-238	6	2.3/8"
	SPL 5°	36184-312	6	3.1/2			SPL 12°	53614-278	6	2.7/8 "
	SPL 5°	36184-400	6	4			SPL 12°	53614-312	6	3.1/2 "
	SPL 5°	36184-412	6	4.1/2			SPL 12°	53614-400	6	4"
	SPL 5°	36184-500	6	5			SPL 12°	53614-412	6	4.1/2 "
	SPL 5°	36184-512	6	5.1/2			200009Y*	200008	SPL 18°	36185-238
200010Y*	SPL 5°	36284-512	6	5.1/2	SPL 18°	36185-278			6	2.7/8 "
	SPL 5°	36248-658	6	6.5/8	SPL 18°	36185-312			6	3.1/2 "
	SPL 5°	36248-700	6	7	SPL 18°	36185-400			6	4 "
	SPL 5°	36248-758	6	7.5/8	SPL 18°	36185-412			6	4.1/2 "
200012Y*	SPL 5°	36186-858	6	8.5/8	200011Y*	200010			SPL 18°	36185-500
	SPL 5°	36186-958	6	9.5/8			SPL 18°	70253-512	6	5.1/2 "
	SPL 5°	36186-978	6	9.7/8			SPL 18°	70253-658	6	6.5/8 "
200013Y*	SPL 5°	36187-107	6	10.3/4						

NOTE: The frame number + tapered insert number determines the actual size of the elevator.  
 E.g. 200008 + 53614-312 = SPL 12° for 3.1/2" pipe becomes 200014Y312.  
 E.g. 200008 + 36184-312 = SPL 5° for 3.1/2" pipe becomes 200008Y312.

## OPTIONAL EQUIPMENT PART NUMBERS

SJL/SPL swivel suspension sling\*

Size	Part number
2.3/8" - 24.1/2"	34568-5

\*Not to be used when rotating with load.



## SBX7, SJX & D-SJX SERIES ELEVATORS

The SBX7 elevator is a solid body elevator with one manually operated door for high loads up to 1,250 sTon. The elevator is suitable in combination with the standard BX7 bushings (see elsewhere in this catalog). This elevator is designed for (ultra-) deep water drilling rigs.

The SJX single joint elevator is designed for running single joints of tubing and casing from V-door to well center. It is double hinged for use with the CRT Casing Running Tool, or any other stabberless operation. Ergonomically designed handles with cast on stop pins prevent the lifting sling shackles from pinching hands.

The D-SJX elevator is the heavy duty version of the SJX elevator, capable of handling doubles and triples up to 12 STon / 10.9 Tonne



SBX7



SJX



D-SJX

### TECHNICAL SPECIFICATIONS SBX7, SJX / D-SJX SERIES

Type	Part number	Load Rating [sTon/Tonne]	Size range [Inches]	Max. Weight [lbs]	Max. Weight [kg]
SJX	50004929Y*	5 / 4.5	2.3/8 – 4.1/2	37	17
SJX	50004931Y*	5 / 4.5	4.1/2 – 7	44	20
SJX	50004933Y*	5 / 4.5	7 – 10	57	26
SJX	50004935Y*	5 / 4.5	10 – 14	67	30
D-SJX	50004955Y*	12 / 10.9	3.25/32 – 6.1/8	79	36
D-SJX	50004958Y*	12 / 10.9	6.1/4 – 8.7/8	89	40
SBX7	50001270Y**	1,250 / 1,133	8 - 9.5/8	4, 546	2,062

\*Refer to bore codes

\*\* See chapter Hydraulic Elevators for available BX7 bushings

### OPTIONAL EQUIPMENT PART NUMBERS

D-SJX swivel suspension sling

Part number
50001105

DSJX 12 sTon with drill pipe 18° insert bore chart

Bore Code	Center Bore C	Pipe	Basic elevator	Insert set
119	3.25/32	3.1/2 Reg, FH +Hydrill	50004955Y	50004948Y119
120	3.31/32	3.1/2 IF	50004955Y	50004948Y120
121	4.9/32	4 FH	50004955Y	50004948Y121
122	4.25/32	4 IF + 4.1/2 Reg + 4.1/2 FH	50004955Y	50004948Y122
123	5.1/4	4.1/2 IF + 5 EIU	50004955Y	50004948Y123
124	5.13/16	5.1/2 REG + FH	50004955Y	50004948Y124
789	6.1/8	5.7/8 IEU	50004955Y	50004948Y789
678	6.233	5.1/2 IF + IEU	50004958Y	50004959Y678
740	7.031	6.5/8 IEU	50004958Y	50004959Y740

DSJX 12 sTon with drill collars with zip lift recess bore chart

Bore Code	Top Bore A	Pipe	Basic elevator	Insert set
177	3.11/16	4.1/8 DC Zip	50004955Y	50004948Y177
674	3.13/16	4.1/4 DC Zip	50004955Y	50004948Y674
554	4.1/16	4.1/2 DC Zip	50004955Y	50004948Y554
466	4.3/8	4.7/8 DC Zip	50004955Y	50004948Y466
609	5	5.5/8 DC Zip	50004955Y	50004948Y609
667	6	6.5/8 DC Zip	50004955Y	50004948Y667
188	6.3/4	7.1/2 DC Zip	50004958Y	50004959Y188
610	7.3/8	8.1/8 DC Zip	50004958Y	50004959Y610
613	7.7/8	8.5/8 DC Zip	50004958Y	50004959Y613
564	8.3/8	91/4 DC Zip	50004958Y	50004959Y564

DSJX 12 sTon with plain drill collars with lift plugs bore chart

Bore Code	Top Bore A	Pipe	Basic elevator	Insert set
211	3.29/32	3.3/4 DC	50004955Y	50004948Y211
763	4.1/32	3.7/8 DC	50004955Y	50004948Y763
213	4.5/32	4 DC	50004955Y	50004948Y213
519	4.9/32	4.1/8 DC	50004955Y	50004948Y519
548	4.13/32	4.1/4 DC	50004955Y	50004948Y548
215	4.21/32	4.1/2 DC	50004955Y	50004948Y215
354	4.15/16	4.3/4 DC	50004955Y	50004948Y354
552	5.3/16	5 DC	50004955Y	50004948Y552
219	5.7/16	5.1/4 DC	50004955Y	50004948Y219
411	5.11/16	5.1/2 DC	50004955Y	50004948Y411
222	5.31/32	5.3/4 DC	50004955Y	50004948Y222
349	6.7/32	6 DC	50004958Y	50004959Y349
348	6.15/32	6.1/4 DC	50004958Y	50004959Y348
331	6.19/32	6.3/8 DC	50004958Y	50004959Y331
765	6.23/32	6.1/2 DC	50004958Y	50004959Y765
338	7	6.3/4 DC	50004958Y	50004959Y338
372	7.1/4	7 DC	50004958Y	50004959Y372
355	7.1/2	7.1/4 DC	50004958Y	50004959Y355
766	7.3/4	7.1/2 DC	50004958Y	50004959Y766
550	8	7.3/4 DC	50004958Y	50004959Y550
334	8.1/4	8 DC	50004958Y	50004959Y334
347	8.1/2	8.1/4 DC	50004958Y	50004959Y347
580	8.25/32	8.1/2 DC	50004958Y	50004959Y580

## SJH SERIES MANUAL ELEVATOR

The SJH horizontal pick up elevator is designed to pick up tubulars lying flat on a surface without having to lift the tubulars prior to closing the elevator. The elevator is capable of lifting drill pipe, recessed/zip lift drill collars and casing. It will handle single joints of pipe straight from cantilever to off-line stand building systems.



### TECHNICAL SPECIFICATIONS

Type	Part number*	Load Rating [sTon/ Tonne]	Size range	Pipe type	Part number Jaws	Appr. weight [lbs / kg] (incl jaws)
SJH	50003135Y*	5 / 4.5	2.3/8" – 4.1/2"	Tbg & Dp	50003148Y*	100 / 45
SJH	50003155Y*	5 / 4.5	4.1/2" – 7.5/8"	Tbg & Dp	50003189Y*	111 / 50.5
SJH	50003175Y*	5 / 4.5	7" – 10.3/4"	Csg	50003151Y*	132

\*Refer to Jaw Bore code # in the following tables.

### SIZE COMPONENTS

Jaws SJH 2.3/8" – 4.1/2" pn 50003135Y\*

Size Tubing	Type upset	90° Bode code #	5° Bode code #	12° Bode code #
2.3/8"	Plain	158	5238	12238
	Upset	159		
2.7/8"	Plain	160	5278	12278
	Upset	161		
3.1/2"	Plain	162	5312	12312
	Upset	163		
4"	Plain	164	5400	12400
	Upset	165		
4.1/2"	Plain	129	5412	12412
	Upset	167		

Size Drill Pipe	Type upset	18° Bode code #
2.3/8"	IU	-
	EU	116
2.7/8"	IU	117
	EU	118
3.1/2"	IU	119
	EU	120
4"	IU	121
	EU	122
4.1/2"	EU	123

Jaws SJH 4.1/2" – 7.5/8" pn 50003155Y\*

Size Casing	90° Bode code #	5° Bode code #
4.1/2"	129	5412
5"	131	5500
5.1/2"	132	5512
5.3/4"	133	-
6"	134	-
6.5/8"	135	5658
7"	136	5700
7.5/8"	137	5758

Size Drill Pipe	Type upset	18° Bode code #
4.1/2"	IU	122
	EU	123
5"	IU	123
5.1/2"	IEU	124
5.7/8" (6" upset)	IEU	789
6.5/8"	IEU	782

Jaws SJH 7" – 10.3/4" pn 50003175Y\*

Size Casing	90° Bode code #	5° Bode code #
4.1/2"	129	na
5"	131	na
5.1/2"	132	na
7"	136	5700
7.5/8"	137	5758
8.5/8"	139	5858
9"	140	5900
9.5/8"	141	5958
10.3/4"	142	51034

# HYDRAULIC ELEVATORS

## BX HYDRAULICALLY ACTUATED ELEVATOR AND UNIVERSAL ROTATOR



### BX 3,4,5 & 7

- Designed for hydraulic actuated operation
- Cost competitive and economic with normal rig complement of air-operated, drill pipe, drill collar and casing elevators.
- Double door design for optimal balance and performance.
- The hydraulic cylinders are located inside the body casting for clean lines and maximum protection, and yet they are accessible for normal maintenance.
- Changeable bushings allow one elevator frame to handle all pipe size and type requirements.
- Bushings are locked into place with spring loaded pins for quick, easy removal and installation.
- Bushings can be changed within 5 minutes.
- No special tools are needed, no loose nuts, bolts or pins.
- Hinge journals are bushed to put major wear into replaceable components.
- One door bushing is spring loaded with linkage connecting it to a locking pin. Any load on this bushing segment engages the pin preventing the elevator from opening. This safety lock prevents the elevator from opening under load.
- Latch valve eliminates any faulty signals.
- The elevator is prepared for an interlock system as an option when used with a power slip.
- A trigger mechanism initiates the closing sequence when pipe is thrown into the elevator.
- Additionally equipped with a rotary actuator and can be tilted to pick up pipe from the V-door, eliminating the need for single joint elevators.

### BXS-SLIP TYPE

- Designed for hydraulic actuated operation.
- Cost competitive and economic with normal rig complement of air-operated casing elevators.
- Double door design for optimal balance and performance.
- The hydraulic cylinders are located inside the body casting for clean lines and maximum protection, and yet they are accessible for normal maintenance.
- Movable replaceable slips allow one elevator frame to handle multiple pipe sizes with no or very small external upset or load shoulder.
- Easy slip exchange.
- No loose nuts, bolts or pins.
- The safety lock prevents the elevator from opening under load.
- Latch valve will prevent any false signals
- The elevator is prepared for an interlock system as an option when used with a power slip.
- Additionally equipped with a rotary actuator and can be tilted to pick up pipe from the V-door, eliminating the need for single joint elevators.

### UX-HORSE SHOE

- The hydraulic UX single joint horizontal pick up elevator, is designed to pick up tubulars lying flat on a scaffold/raised support beam without having to lift the tubulars prior to closing the elevator.
- The elevator is capable of lifting casing.
- It will handle single joints of pipe straight from cantilever to off-line stand building system, and is used underneath the CRT350/500 casing running tool as for picking up tubulars from the V-door.
- After picking up the pipe, the pipe weight is transferred to the top collar plate.
- The jaws do not carry the vertical load.
- The jaws are delivered in sets and cover the range from 4.1/2" - 20".
- The top collar plates and bottom guides must be ordered separately.

### H-SJH-TYPE

- Hoist joints and/or stands of tubulars (drill pipe, casing or tubing) during the stand building operations of the total CRT350.
- Pick up single tubulars from the V-door or the catwalk (pipe deck) and hoist them into the derrick and vice versa.



### UNIVERSAL ROTATOR

- Hydraulic actuated operation.
- Strong, reliable, economic.
- Single hydraulic line required for rotation, accumulator actuated return movement.
- The hydraulic cylinder is located inside the body for clean lines and maximum protection.
- No loose nuts, bolts or pins.
- Easy adjustment of angle.
- Safe and reliable picking up pipe from the V-door, eliminating the need for single joint elevators.

# BX HYDRAULICALLY ACTUATED ELEVATOR

## TECHNICAL SPECIFICATIONS

Type	Part no.	Size range	Weight (w/o bushings) [lbs/kg]	Load Rating of the elevator			Link size	
				18° Tool Joint [sTon/Tonne]	90° Coupling [sTon/Tonne]	45° Coupling [sTon/Tonne]	Min	Max
BX3	203300Y30	9.5/8" - 20"	2,165 / 975	n/a	350 / 318	-	2.3/4"	3.1/2"
BX4-35	50005300Y	2.3/8" - 7.1/4"	1,400 / 635	350 / 318	350 / 318	-	2.3/4"	4.3/4"
BX4-50	50000640Y	2.3/8" - 9.3/4"	2,039 / 924	500 / 453	500 / 453	-	2.3/4"	4.3/4"
BX4-75	50000650Y	2.3/8" - 9.3/4"	2,047 / 928	500 / 453	750 / 680	-	3.1/2"	4.3/4"
BX5	50004000Y40	3.1/2" - 11"	3,295 / 1,495	750 / 680	1000 / 907	-	4.3/4"	5.1/2"
BX7	50000580Y10	5" - 9.5/8"	2,030 / 4,475	750 / 1,000	1,250 / 1,133	1,250 / 1,133	5.1/2" *	5.1/2" *

\* 1,250 sTon links only

Type	Part no.	Size range	Weight (w/o slips) [lbs/kg]	Load Rating of the elevator	Link size	
					Min	Max
BXS * (slip type)	50000202Y	2.3/8" - 7.5/8"	2,730 / 1,238	350 / 317	2.3/4"	4.3/4"

\* Stand alone Control Panel, refer to chapter "Power Units and Control Panels"

### Power requirements BX, BXS elevators and Rotators

Description	
Min Pressure [psi/kPa]	2,000 / 13,789
Max Pressure [psi/kPa]	2,500 / 17,236
Flow rate [gpm/lpm]	5 / 19
Hydraulic lines	3 @ 1/2" w/o rotator 5 @ 1/2" w/ rotator

## ROTATORS

The rotator is a tool designed for rotating the BX series elevators, used e.g. when picking up a pipe from the V-door. The rotator is hydraulically driven via the rotating head and is operated via the drillers console. The float function enables the elevator to follow a changing pipe angle without any interference of the operator, as the float command overrides all manual rotator commands. Especially for BX4 i.c.w. TDS-11 top drives, a narrow type is available.

### TECHNICAL SPECIFICATIONS

Type	Dimensions LxWxH [inches/mm]	Weight [lbs/kg]
Rotator	15 x 8 x 37 / 381 x 203 x 940	330 / 150
Rotator for BX4 i.c.w. TDS-11	18.8 x 11.1 x 68.5 / 478 x 282 x 1740	407 / 185
Rotator for BX7	18.8 x 11.1 x 68.5 / 478 x 282 x 1740 (twice)	814 / 370

Type	Link size [inches]	
Rotator	Min 2.3/4"	Max 4.3/4"
Rotator for BX4 i.c.w. TDS-11	Min 3.1/2"	Max 4.1/2"

## MAIN PART NUMBERS

### Rotator

Part number	Description
50004130	Rotator (single arm)
50004100-1	Wear buttons for 5,75" links (750 sTon)
50004100-2	Wear buttons for 4,5" links (500 sTon)
50004100-3	Wear buttons for 3,5" links (350 sTon)
50004100-4	Wear buttons for 6,25" links (1000 sTon)
50004100-340	Link block adapter for BX3 & BX4
50004077-50	Link block adapter for BX5

### Rotator for BX-4 i.c.w. TDS-11

Part number	Description
50004170	Rotator i.c.w. TDS-11 (single arm)
50004170-500	Wear buttons for 4,5" links (500 sTon)
50004170-350	Wear buttons for 3,5" links (350 sTon)
50004100-340	Link block adapter for BX3 & BX4

### Rotator for BX-7

Part number	Description
50004160	Double sided Rotator (double arms)
50004100-4	Wear buttons for 6,25" links (1000 sTon)
50004077-50	Link block adapter kit for BX7

Hydraulic requirements: See BX-elevator specifications



### SIZE COMPONENTS BXS

Size [inches]	Part number Slip carrier	Insert	Qty. inserts	Dimension insert [inches]
2.7/8 - 2.3/8 pn 50000205				
2.7/8	50000205Y1	24773	12	3"x2
2.3/8	50000205Y2	29255	12	3"x2"
3.1/2" - 2.7/8 pn 50000206				
3.1/2	50000206Y1	24774	24	3"x1.25"
2.7/8	50000206Y2	30358	24	3"x1.25"
4.1/2 - 3.1/2 pn 50000207				
4.1/2	50000207Y1	2165	24	2.75"x 1.29"
4	50000207Y2	2164	24	2.75"x 1.29"
3.1/2	50000207Y3	2163	24	2.75"x 1.29"
5.1/2 - 4.1/2 pn 50000208				
5.1/2	50000208Y1	2170	24	2.75"x 1.29"
5	50000208Y2	2169	24	2.75"x 1.29"
4.1/2	50000208Y3	2168	24	2.75"x 1.29"
4 3/4	50000208Y4	2638	24	2.75"x 1.29"
6.1/2 - 5.5/8 pn 50000209				
6.1/2	50000209Y1	2173	36	2.75"x 1.29"
6.1/8	50000209Y2	2172	36	2.75"x 1.29"
6	50000209Y3	2169	36	2.75"x 1.29"
5.7/8	50000209Y4	2623	36	2.75"x 1.29"
5.5/8	50000209Y5	2650	36	2.75"x 1.29"
7.5/8 - 6.5/8 pn 50000210				
7.5/8	50000210Y1	2633	36	2.75"x 1.29"
7	50000210Y2	2623	36	2.75"x 1.29"
6.5/8	50000210Y3	2632	36	2.75"x 1.29"

### SIZE COMPONENTS BX3

Casing Bushing			Drill collar Plain		
Size	Part number	Load Rating [sTon/Tonne]	Size	Part number	Load Rating [sTon/Tonne]
9.5/8"	203310Y141	350 / 318	10" DC Plain	203312Y228	150 / 136
9.7/8"	203310Y649	350 / 318	10.1/2" DC Plain	203312Y229	150 / 136
10.3/4"	203310Y142	350 / 318	11" DC Plain	203312Y230	150 / 136
10.5/8"	203310Y453	350 / 318			
11.3/4"	203310Y143	350 / 318			
11.7/8"	203310Y729	350 / 318			
12.3/4"	203310Y345	350 / 318			
12.7/8"	203310Y676	350 / 318			
13.3/8"	203310Y144	350 / 318			
13.5/8"	203310Y596	350 / 318			
14"	203310Y690	350 / 318			
16"	203310Y145	350 / 318			
16.3/4"	203310Y664	350 / 318			
18"	203310Y723	350 / 318			
18.5/8"	203310Y146	350 / 318			
20"	203310Y147	350 / 318			

## SIZE COMPONENTS BX4-35

Casing Bushing		
Description	Part number	Load Rating [sTon/Tonne]
4.1/2" Csg / Tubing plain	50005351Y129	350 / 318
5" Casing	50005351Y131	350 / 318
5.1/2" Casing	50005351Y132	350 / 318
6.5/8" Casing	50005351Y135	350 / 318
7" Casing	50005351Y136	350 / 318
Tubing Bushing		
Description	Part number	Load Rating [sTon/Tonne]
2.3/8" Casing/Plain Tubing	50005351Y158	350 / 318
2.3/8" EU Tubing	50005351Y159	350 / 318
2.7/8" Plain Tubing	50005351Y160	350 / 318
2.7/8" EU Tubing	50005351Y161	350 / 318
3.1/2" Casing/Plain Tubing	50005351Y162	350 / 318
3.1/2" EU Tubing	50005351Y163	350 / 318
4" Plain Tubing	50005351Y164	350 / 318
4" EU Tubing	50005351Y165	350 / 318
4.1/2" EU Tubing	50005351Y167	350 / 318
Drill Collars Zip Lift		
Description	Part number	Load Rating [sTon/Tonne]
3.1/8" DC w/ Zip Lift	50005352Y735	150 / 136
3.3/8" DC w/ Zip Lift	50005352Y736	150 / 136
3.1/2" DC w/ Zip Lift	50005352Y625	150 / 136
4.1/8" DC w/ Zip Lift	50005352Y177	150 / 136
4.3/4" DC w/ Zip Lift	50005352Y435	150 / 136
5.1/4" DC w/ Zip Lift	50005352Y179	150 / 136
5.1/2" DC w/ Zip Lift	50005352Y180	150 / 136
5.3/4" DC w/ Zip Lift	50005352Y181	150 / 136
6" DC w/ Zip Lift	50005352Y362	150 / 136
6.1/4" DC w/ Zip Lift	50005352Y337	150 / 136
6.1/2" DC w/ Zip Lift	50005352Y373	150 / 136
6.3/4" DC w/ Zip Lift	50005352Y387	150 / 136
7" DC w/ Zip Lift	50005352Y361	150 / 136
7.1/4" DC w/ Zip Lift	50005352Y357	150 / 136
Drill Pipe Bushings		
Description	Part number	Load Rating [sTon/Tonne]
2.7/8" IU DP	50005353Y117	350 / 318
2.7/8" EU DP	50005353Y118	350 / 318
3.1/2" IU DP	50005353Y119	350 / 318
3.1/2" EU DP	50005353Y120	350 / 318
4" IU DP	50005353Y121	350 / 318
4" EU, 4 1/2" IU & 4 1/2" IEU DP	50005353Y122	350 / 318
4.1/2" EU & 5" IEU DP	50005353Y123	350 / 318
4.1/2" IEU DP	50005353Y124	350 / 318

Drill Collars Plain (zip lift)		
Description	Part number	Load Rating [sTon/Tonne]
2.1/2" DC PLAIN	50005354Y201	150 / 136
2.3/4" DC PLAIN	50005354Y203	150 / 136
3" DC PLAIN	50005354Y205	150 / 136
3.1/8" DC PLAIN	50005354Y206	150 / 136
3.1/4" DC PLAIN	50005354Y207	150 / 136
3.1/2" DC PLAIN	50005354Y209	150 / 136
3.3/4" DC PLAIN	50005354Y211	150 / 136
4" DC PLAIN	50005354Y213	150 / 136
4.1/8" DC PLAIN	50005354Y519	150 / 136
4.1/4" DC PLAIN	50005354Y548	150 / 136
4.1/2" DC PLAIN	50005354Y215	150 / 136
4.3/4" DC PLAIN	50005354Y354	150 / 136
5" DC PLAIN	50005354Y552	150 / 136
5.1/4" DC PLAIN	50005354Y219	150 / 136
5.1/2" DC PLAIN	50005354Y411	150 / 136
5.3/4" DC PLAIN	50005354Y222	150 / 136
6" DC PLAIN	50005354Y349	150 / 136
6.1/4" DC PLAIN	50005354Y348	150 / 136
6.3/8" DC PLAIN	50005354Y331	150 / 136
6.1/2" DC PLAIN	50005354Y765	150 / 136
6.3/4" DC PLAIN	50005354Y338	150 / 136
7" DC PLAIN	50005354Y372	150 / 136
7.1/4" DC PLAIN	50005354Y355	150 / 136



## SIZE COMPONENTS BX4-50, 4-75

NOTE: Mid 2009 some bushings have been replaced by modified bushings. The old and new bushings are interchangeable, however, when ordering bushings, customer will always receive the new bushings with new part numbers.

DC w/Zip Lift Bushing		
Description	Part number	Load Rating [sTon/Tonne]
5.1/4" DC w/Zip Lift	50000677Y179	150 / 136
5.1/2" DC w/Zip Lift	50000677Y180	150 / 136
6.1/4" DC w/Zip Lift	50000677Y337	150 / 136
6" DC w/Zip Lift	50000677Y362	150 / 136
6.1/2" DC w/Zip Lift	50000677Y373	150 / 136
6.3/8" DC w/Zip Lift	50000677Y409	150 / 136
4.3/4" DC w/Zip Lift	50000677Y435	150 / 136
5" DC w/Zip Lift	50000677Y530	150 / 136
8" DC w/Zip Lift	50000677Y336	150 / 136
7.3/4" DC w/Zip Lift	50000677Y339	150 / 136
7.1/4" DC w/Zip Lift	50000677Y357	150 / 136
7" DC w/Zip Lift	50000677Y361	150 / 136
6.3/4" DC w/Zip Lift	50000677Y387	150 / 136
8.1/4" DC w/Zip Lift	50000677Y422	150 / 136
10" DC w/Zip Lift	50000677Y195	150 / 136
9.3/4" DC w/Zip Lift	50000677Y367	150 / 136
9.1/2" DC w/Zip Lift	50000677Y370	150 / 136
8.1/2" DC w/Zip Lift	50000677Y426	150 / 136
9" DC w/Zip Lift	50000677Y427	150 / 136
8.3/4" DC w/Zip Lift	50000677Y553	150 / 136
4.1/8" DC w/Zip Lift	203211Y177	150 / 136
3.1/2" DC w/Zip Lift	203211Y625	150 / 136
4.1/4" DC w/Zip Lift	203211Y674	150 / 136
3.1/8" DC w/Zip Lift	203211Y735	150 / 136
3.3/8" DC w/Zip Lift	203211Y736	150 / 136

Riser Handling Bushing		
Description	Part number	Load Rating [sTon/Tonne]
6.5/8" Riser Handling	50000676Y333	750 / 608
7.1/4" Riser Handling	50000676Y885	750 / 608
8" Riser Handling	50000676Y884	750 / 608
8.3/4" Riser Handling	50000676Y783	750 / 608
8.5/8" Riser Handling	50000676Y784	750 / 608
9.5/8" Riser Handling	50000676Y788	750 / 608
7" Riser Handling	50000676Y790	750 / 608
Special 55.deg, 8.5/8" Riser	50000676Y869	750 / 608

Tubing Bushing		
Description	Part number	Load Rating [sTon/Tonne]
2.3/8" Casing / Plain Tbg.	203210Y158	500 / 453
2.3/8" OD.EU. Tbg.	203210Y159	500 / 453
2.7/8" Plain Tbg.	203210Y160	500 / 453
2.7/8" OD. EU. Tbg.	203210Y161	500 / 453
3.1/2" Casing / Plain Tbg.	203210Y162	500 / 453
3.1/2" OD. EU. Tbg.	203210Y163	500 / 453
4" OD. Plain Tbg.	203210Y164	500 / 453
4" OD. EU. Tbg.	203210Y165	500 / 453
2.88" Special Gun tube	203210Y867	500 / 453
3.50" Special Gun tube	203210Y868	500 / 453

Square Shoulder DP		
Description	Part number	Load Rating [sTon/Tonne]
5" IEU Sq. Shoulder DP	50000675Y106	750 / 608
5.1/2" IEU Sq. Shoulder DP	50000675Y107	750 / 608
2.7/8" EU Sq. Shoulder DP	203212Y101	500 / 453
3.1/2" IU Sq. Shoulder DP	203212Y102	500 / 453
3.1/2" EU Sq. Shoulder DP	203212Y103	500 / 453
4" IU Sq. Shoulder DP	203212Y104	500 / 453

Casing Bushings		
Description	Part number	Load Rating [sTon/Tonne]
4.1/2" Casing / Plaine Tbg.	50000676Y129	750 / 608
5" Casing	50000676Y131	750 / 608
5.1/2" Casing	50000676Y132	750 / 608
6" Casing	50000676Y134	750 / 608
6.5/8" Casing	50000676Y135	750 / 608
7" Casing	50000676Y136	750 / 608
7.5/8" Casing	50000676Y137	750 / 608
8.5/8" Casing	50000676Y139	750 / 608
9.5/8" Casing	50000676Y141	750 / 608
4.1/2" OD. EU. Tbg.	50000676Y167	750 / 608
6.1/4" Casing	50000676Y505	750 / 608
1/16" Bevel 7-1/4" Casing	50000676Y563	750 / 608
9.7/8" Casing	50000676Y649	750 / 608
7.3/4" Casing	50000676Y705	750 / 608
8" Casing	50000676Y757	750 / 608
8.3/4" Casing	50000676Y804	750 / 608
4.1/2" Casing / Plaine Tbg.	50000676Y848	750 / 608
6.7/8" 55",45",35" Taper	50000676Y834	750 / 608
7" HyDrill 521 #26 w/ Lift plug	50000676Y854	750 / 608
9.1/8" Casing	50000676Y883	750 / 608

## SIZE COMPONENTS BX4-50, 4-75

DP bushing		
Description	Part number	Load Rating [sTon/Tonne]
2.7/8" IU DP	50000675Y117	500 / 453
2.7/8" EU DP	50000675Y118	500 / 453
3.1/2" IU DP	50000675Y119	500 / 453
3.1/2" EU DP	50000675Y776	500 / 453
4" IU DP	50000675Y777	500 / 453
4" EU & 4.1/2" IEU DP	50000675Y778	500 / 453
4.1/2" EU & 5" IEU DP	50000675Y779	500 / 453
5.1/2" IEU DP	50000675Y780	500 / 453
5.1/2" IF IEU DP	50000675Y781	500 / 453
6.5/8" IEU DP	50000675Y782	500 / 453
5.7/8" DP 18degr (6"EU MAX.)	50000675Y789	500 / 453
4" DP with 4.1" max upset	50000675Y798	500 / 453
6.5/8" DP 7.1/8" upset	50000675Y823	500 / 453
SK5.1/2" special DP	50000675Y880	

## SIZE COMPONENTS BX5

Casing Bushing		
Size	Part number	Load Rating [sTon/Tonne]
4.1/2"	50004010Y129	750 / 680
4.3/4"	50004010Y130	750 / 680
5"	50004010Y131	750 / 680
5.1/2"	50004010Y132	750 / 680
5.3/4"	50004010Y133	750 / 680
6	50004010Y134	750 / 680
6 5/8"	50004010Y135	750 / 680
7"	50004010Y136	750 / 680
7.5/8"	50004010Y137	750 / 680
7.3/4"	50004010Y705	750 / 680
8.5/8"	50004010Y139	750 / 680
9.5/8"	50004010Y141	750 / 680
9.7/8"	50004010Y649	750 / 680
10.3/4"	50004010Y142	750 / 680

DC Plain bushing		
Description	Part number	Load Rating [sTon/Tonne]
6" DC Plain	50000678Y349	150 / 136
4.3/4" DC Plain	50000678Y354	150 / 136
6.1/2" DC Plain	50000678Y765*	150 / 136
6.3/4" DC Plain	50000678Y338	150 / 136
6.1/4" DC Plain	50000678Y348	150 / 136
8" DC Plain	50000678Y334	150 / 136
9.1/2" DC Plain	50000678Y346	150 / 136
8.1/4" DC Plain	50000678Y347	150 / 136
9" DC Plain	50000678Y356	150 / 136
8.1/2" DC Plain	50000678Y580	150 / 136
2.1/2" DC Plain	203213Y201	150 / 136
2.3/4" DC Plain	203213Y203	150 / 136
3" DC Plain	203213Y205	150 / 136
3.1/8" DC Plain	203213Y206	150 / 136
3.1/4" DC Plain	203213Y207	150 / 136
3.1/2" DC Plain	203213Y209	150 / 136
3.3/4" DC Plain	203213Y211	150 / 136
4.1/8" DC Plain	203213Y519	150 / 136
4.1/4" DC Plain	203213Y548	150 / 136
3.3/8" DC Plain	203213Y795	150 / 136

Drill collars Zip Lift Bushing		
Size	Part number	Load Rating [sTon/Tonne]
4.3/4"	50004011Y435	150 / 136
6"	50004011Y362	150 / 136
6.1/4 "	50004011Y337	150 / 136
6.1/2"	50004011Y373	150 / 136
6.3/4"	50004011Y387	150 / 136
7.3/4"	50004011Y339	150 / 136
8"	50004011Y336	150 / 136
8.1/4"	50004011Y422	150 / 136
8.1/2"	50004011Y426	150 / 136
9"	50004011Y427	150 / 136
9.1/2"	50004011Y370	150 / 136
9.3/4"	50004011Y367	150 / 136
10"	50004011Y195	150 / 136
10.3/4"	50004011Y527	150 / 136
11"	50004011Y419	150 / 136

Drill pipe Bushing		
Size	Part number	Load Rating [sTon/Tonne]
3.1/2" EU Drill	50004012Y776	750 / 680
4" IU Drill	50004012Y777	750 / 680
4" EU & 4 1/2 " IEU	50004012Y778	750 / 680
4.1/2" EU & 5" IEU	50004012Y779	750 / 680
5.1/2" IEU 18°	50004012Y780	750 / 680
5.1/2" DP IF	50004012Y781	750 / 680

SIZE COMPONENTS BX5

Drill pipe Bushing

Size	Part number	Load Rating [sTon/Tonne]
6.5/8" IEU Drill	50004012Y782	750 / 680
5.7/8" EU	50004012Y789	750 / 680

Drill collars plain (lift-plug) Bushing

Size	Part number	Load Rating [sTon/Tonne]
4.3/4" Plain Drill	50004013Y354	150 / 136
5.1/4" Plain Drill	50004013Y219	150 / 136
6.1/4" Plain Drill	50004013Y348	150 / 136
6.1/2" Plain Drill	50004013Y135	150 / 136
8" Plain Drill	50004013Y334	150 / 136
8.1/4" Plain Drill	50004013Y347	150 / 136
8.1/2" Plain Drill	50004013Y357	150 / 136
9" Plain Drill	50004013Y356	150 / 136
9.1/2" Plain Drill	50004013Y346	150 / 136
10" Plain Drill	50004013Y228	150 / 136
10.1/2" Plain Drill	50004013Y229	150 / 136
11" Plain Drill	50004013Y230	150 / 136

Special square shoulder Bushing

Size	Part number	Load Rating [sTon/Tonne]
8"	50004014Y757	1000 / 907
8.3/4"	50004014Y783	1000 / 907
8.5/8"	50004014Y784	1000 / 907
9.5/8"	50004014Y788	1000 / 907

SIZE COMPONENTS BX7

Casing Bushing 1,250 sTon

Size	Part number	Weight lbs (kg)
6.5/8"	50000314Y135	414 (187)
7"	50000314Y136	406 (183)
7.5/8"	50000314Y137	397 (197)
7.3/4"	50000314Y705	390 (176)
8"	50000314Y757	413 (187)
8.5/8"	50000314Y139	383 (174)
8.3/4"	50000314Y804	376 (171)
9.1/8"	50000314Y883	357 (162)
9.5/8"	50000314Y141	329 (149)
9.7/8"	50000314Y142	315 (143)

Drill pipe 18" Bushing 750 sTon

Size	Part number	Weight lbs (kg)
5.1/2" IEU	50000312Y780	468 (212)
5.1/2" IF	50000312Y781	456 (207)

Drill pipe 18" Bushing 1,000 sTon

Size	Part number	Weight lbs (kg)
5.7/8" DP 6" upset	50000312Y789	460 (209)
6.5/8" IEU drill	50000312Y782	428 (194)
6.5/8", with 7.1/8" upset	50000312Y823	421 (191)

Drill collars plain (lift-plug) Bushing

Size	Part number	Weight lbs (kg)
6.5/8"	50000314Y832	431 (196)
6.5/8" WITH RADIUS 1.5"	50000314Y870	433 (197)

Special square shoulder Bushing

Size	Part number	Weight lbs (kg)
8"	50000314Y884	413 (187)
8.3/4"	50000314Y783	377 (171)
8.5/8"	50000314Y784	384 (174)
9.5/8"	50000314Y788	331 (150)
9.28" 15° tapered	50000314Y902	350 (160)
9.4"	50000314Y893	333 (141)

## HYDRAULIC PICK UP ELEVATOR

The hydraulic SJH and UX single joint horizontal pick up elevator, designed to pick up tubulars lying flat on a surface without having to lift the tubular prior to closing the elevator. The elevator is capable of lifting casing with a lifting collar or nubbin. It will handle single joints of pipe straight from cantilever to off-line stand building system, and is used underneath the CRT350 Casing Running Tool (H-SJH) and CRT500 Casing Running Tool (UX) as a standard for picking up elevators from the V-door. The jaws are delivered in sets and cover the range from 4.1/2" - 20". For the CRT350 Casing Running Tool the size 9.5/8" is the maximum.



### TECHNICAL SPECIFICATIONS

Description	H-SJH	UX5-14	UX5-20
Size [inches]	4.1/2" – 10.3/4"	9.5/8" – 14"	16" – 20"
Size with CRT350 [inches]	max 9.5/8"	9.5/8" – 14"	16" – 20"
Load Rating [sTon/ Tonne]	5 / 4.5	5 / 4.5	5 / 4.5
Load Rating 4.1/2" to 5.1/2" [sTon / Tonne]	3 / 2.7	n/a	n/a
Flow [gpm/lpm]	2 to 5 / 7.5 to 18.9	2 to 5 / 7.5 to 18.9	2 to 5 / 7.5 to 18.9
Max. pressure [psi/kPa]	2,500 / 17,236	2,500 / 17,236	2,500 / 17,236
Min. pressure [psi/kPa]	2,000 / 13,789	2,000 / 13,789	2,000 / 13,789
BX type controls	3 control lines (P - T - Xp)	3 control lines (P - T - Xp)	3 control lines (P - T - Xp)
Elevator latched feed-back signal	Jaw & Latch closed verification	Jaw & Latch closed verification	Jaw & Latch closed verification

### MAIN PART NUMBER

H-SJH	UX5-14	UX5-20
50003275Y	50002400Y	50002450Y

### SIZE COMPONENTS

Size Casing	Rating [sTons / Tons]	H-SJH	UX		
		Jaw sets	Jaw set	Top collar	Bottom guide
4.1/2"	3 / 2.72	50003151Y129			
5"	3 / 2.72	50003151Y131			
5.1/2"	3 / 2.72	50003151Y132			
6.5/8"	5 / 4.54	50003151Y135			
7"	5 / 4.54	50003151Y136			
7.5/8"	5 / 4.54	50003151Y137			
7.3/4"	5 / 4.54	50003151Y705			
8.5/8"	5 / 4.54	50003151Y139			
8.3/4"	5 / 4.54	50003151Y804			
9.5/8"	5 / 4.54	50003151Y141			
9.3/4" *	5 / 4.54	50003151Y769			
9.7/8" *	5 / 4.54	50003151Y649			
9.5/8"	5 / 4.54		50005955Y141	50005954Y141	50005959-141
9.7/8"	5 / 4.54		50005955Y649	50005954Y649	50005959-649
10"	5 / 4.54		50005955Y831	50005954Y831	50005959-831
10.1/8"	5 / 4.54		50005955Y846	50005954Y846	50005959-846
10.3/4"	5 / 4.54		50005955Y142	50005954Y142	50005959-142
11.3/4"	5 / 4.54		50005955Y143	50005954Y143	50005959-143
13.3/8"	5 / 4.54		50005955Y144	50005954Y144	50005959-144
13.5/8"	5 / 4.54		50005955Y596	50005954Y596	50005959-596
14"	5 / 4.54		50005955Y690	50005954Y690	50005959-690
16"	5 / 4.54		50002475Y145	50002476Y145	50002477-145
18"	5 / 4.54		50002475Y723	50002476Y723	50002477-723
18.5/8"	5 / 4.54		50002475Y146	50002476Y146	50002477-146
20"	5 / 4.54		50002475Y147	50002476Y147	50002477-147

\* on request



# FMS + ELEVATOR / SPIDERS



**Back up torque for FMS275 only**

Hydraulic Working Pressure (psi)	Power Down Force (sTon)	Applied Maximum Back-up Torque [ft.lbs / Nm] *	
3,000	17.24	17,240	23,373
2,500	14.37	14,370	19,483
2,000	12.49	11,490	15,578
1,500	8.62	8,620	11,687

\* On 7.5/8" OD pipe

**Back up torque for FMS375 only**

Hydraulic Working Pressure (psi)	Power Down Force (sTon)	Applied Maximum Back-up Torque [ft.lbs / Nm]	
2,500	47	40,000	54,232
2,200	41	35,200	47,724
2,000	38	32,000	43,386
1,800	34	28,800	39,047
1,600	30	25,600	34,708
1,400	26	22,400	30,370

**TECHNICAL SPECIFICATIONS MANUAL & PNEUMATIC ELEVATOR/SPIDERS**

	250 BJ 7.5/8"	350 BJ 13.5/8"	500 sTon 14"	500 sTon 24.1/2"	750 sTon 14"	750 sTon 24.1/2"	1000 sTon 24.1/2"
Weight* without slip assembly [lbs/kg]	2,043 / 927	3,500 / 1,587	4,850 / 2,200	7,950 / 3,606	7,500 / 3,402	9,500 / 4,275	9,500 / 4,275
Weight* slips set w/ inserts [lbs/kg]	550 / 250	650 / 295	360 - 600 / 163 - 272	360 - 600 / 163 - 272	360 - 600 / 163 - 272	360 - 600 / 163 - 272	360 - 600 / 163 - 272
Load Rating [sTon/Tonne]	250 / 226	350 / 317	500 / 453	500 / 453	750 / 680	750 / 680	1000 / 907
Casing size range [inches]	2.3/8"-7.5/8"	4.1/2"-13.5/8"	4.1/2" - 14"	16" - 24.1/2"	6.5/8" - 14"	16" - 24.1/2"	16" - 24.1/2"
Normal Operating pressure [psi/kPa]*	85 / 585	85 / 585	85 / 585	85 / 585	85 / 585	85 / 585	85 / 585
Maximum Operating pressure [psi/kPa]*	125 / 861	125 / 861	125 / 861	125 / 861	125 / 861	125 / 861	125 / 861

\* Applicable for pneumatic only

**TECHNICAL SPECIFICATIONS HYDRAULIC ELEVATOR/SPIDERS**

	500 sTon 14"	500 sTon 24.1/2"	750 sTon 14"	750 sTon 24.1/2"
Weight without slip assembly [lbs/kg]	5,392 / 2,446	9,500 / 4,275	7,500 / 3,402	9,500 / 4,275
Weight slips set w/ inserts [lbs/kg]	360 - 600 / 163 - 272	360 - 600 / 163 - 272	360 - 600 / 163 - 272	360 - 600 / 163 - 272
Casing size [inches]	4.1/2" - 14"	16" - 24.1/2"	6.5/8" - 14"	16" - 24.1/2"
Load Rating [sTon/Tonne]	500 / 454	500 / 454	750 / 680	750 / 680
Rotary size [inches]	-	-	-	-
Minimum inlet pressure [psi/kPa]		1,500 / 10,342		
Normal Operating pressure [psi/kPa]		2,000 / 13,789		
Maximum Operating pressure [psi/kPa]		2,500 / 17,236		
For a cycle time of appr. 4 to 5 seconds, the following flow and pressure is required		5 gpm@2,000 psi to 12 gpm@1,000 psi 19 lpm@13,789 kPa to 45 lpm@6,895 kPa		
Recommended inlet pressure Slips UP [psi/kPa]		500-750 / 3,447-5,171		
Maximum pressure Slips UP [psi/kPa]		1,000 / 6,895		
Maximum pressure Slips Down [psi/kPa]		2,500 / 13,789		
Minimum pressure differential between pressure line and return line [psi/kPa]		200 / 1,378		
Maximum allowed pressure in return line [psi/kPa]		200 / 1,378		

**E/S REMOTE OPERATION**

Air operated versions can be remote controlled, please contact your NOV supplier for details



## BJ TYPE ELEVATOR/SPIDER 7.5/8" 250 TON & FMS275 FLUSH MOUNTED SLIP

### MAIN PART NUMBERS 7.5/8" 250 TON E/S

Part Number	Description
50364Y	Assembly complete, manual
50006260Y	Assembly complete, air operated
31021	Guide Bell Assembly, elevator
50422-2	Upper Guard Assembly, spider
31008	Spider Adapter Plate
52384	Hose assembly, elevator
23602	Hose assembly, spider

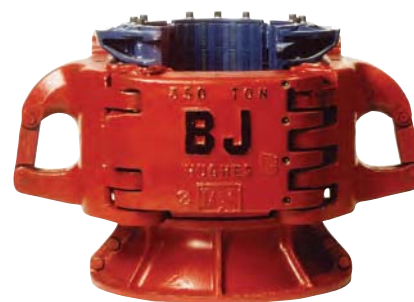

7.5/8" E/S 250 ton



FMS 275

### MAIN PART NUMBERS FMS275

Part Number	Description
50005200	Assembly complete, hydraulically operated

### OPTIONAL EQUIPMENT PART NUMBERS FMS275

Part Number	Description
50004994	Hinged adapter 37.1/2" Emsco to 27.1/2" API
50004998	Hinged adapter 37.1/2" National to 27.1/2" API
50004999	Hinged adapter 37.1/2" Oilwell to 27.1/2" API
59000300	Lifting sling for FMS275
50005248-10	Control valve for FMS275
50005249	Jumper hose kit control valve to FMS275
50006261	Conversion kit Manual-to-Air Operated E/S

### SLIPS, INSERTS, RETAINERS & GUIDES FMS275 & 250 TON ELEVATOR/SPIDER

Pipe Size, [inches]	Slip Size, [inches]	PARTS					GUIDES	
		Slip Ass'y. Part Number.	Insert Part Number	Qty. of insert	Slip Hanger Kit *	Insert Retainer Part Number	Bottom Guide Plate Assembly Part No.	Top Guide Plate Assembly Part No.
2.3/8"	3.1/2"	50006291Y238	24777	18	50005241	31003	51925	51920
2.7/8"	"	50006291Y278	25780	18	50005241	31004	51925	51920
3.1/2"	"	50006291Y312	16441	18	50005241	31005	51925	51920
3.1/2"	4.1/2"	50006292Y312	24779	27	50005242	31177	51926	51921
4"	"	50006292Y400	24781	27	50005242	31177	51926	51921
4.1/2"	"	50006292Y412	BJ16408	27	50005242	31177	51926	51921
4.1/2"	5.1/2"	50006293Y412	24785	27	50005243	31014	51927	51922
5"	"	50006293Y500	24783	27	50005243	31013	51927	51922
5.1/2"	"	50006293Y512	BJ16407	27	50005243	31012	51927	51922
6.5/8"	7.5/8"	50006294Y658	25474	45	50005244	31011	51928	51924
7"	"	50006294Y700	26750	45	50005244	31010	51928	51924
7.5/8"	"	50006294Y758	BJ16407	45	50005244	31009	51928	51924

\* FMS only

## BJ TYPE ELEVATOR/SPIDER 13.5/8" 350 TON

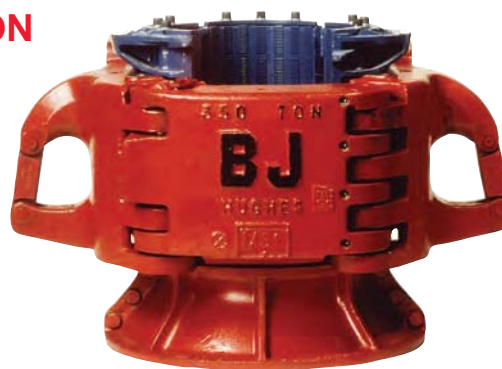

### MAIN PART NUMBERS

Part Number	Description
34301Y	Assembly complete: manually operated
33492Y	Assembly complete, air operated
52384	Hose assembly, elevator
23602	Hose assembly, spider
28599	Guide Bell Assembly, elevator
28570-1	Upper Guard Assembly, spider
27000	Spider Adapter Plate 27.1/2" RT
31100	Spider Adapter Plate 37.1/2" RT (except Emsco)
32698	Spider Adapter Plate 37.1/2" RT (Emsco s/n < 49)
34050	Spider Adapter Plate 37.1/2" RT (Emsco s/n > 48)
50006276	Conversion kit Manual-to-Air operated

### SLIPS, GUIDES & INSERTS 350 TON ELEVATOR/SPIDER

Pipe size [inches]	Slip size (nominal) [inches]	PARTS			GUIDES		
		Slip assembly Part Number	Insert Part Number	Qty	Insert retainer Part Number	Bottom guide plate assembly Part Number	Top guide plate assembly Part Number
4.1/2"	6"	50006480Y412	31157	36	50006479	51936	51949
5"	"	50006480Y500	24785	36	50006479	51936	51950
5.1/2"	"	50006480Y512	24781	36	50006479	51936	51950
5.3/4"	"	50006480Y534	50006544	36	50006479	28568 & 28578	51951
6"	"	50006480Y600	BJ16407	48	50006479	28568 & 28578	51951
6.5/8"	8"	50006485Y658	31157	60	50006484	51937	51952
7"	"	50006485Y700	25474	60	50006484	51937	51952
7.5/8"	"	50006485Y758	24748	60	50006484	51938	51953
8.5/8"	8.5/8"	50006785Y858	15660	60	50006484-1	51939	51954
9.5/8"	10.3/4"	50006490Y958	33249	72	50006489	51940	51955
10.3/4"	"	50006490Y1034	15660	72	50006489	51941	51956
11.3/4"	13.3/8"	50006495Y1134	50006545	84	28581	51941	51957
12.3/4"	"	50006495Y1234	32700	84	28581	51942	51958
13.3/8"	"	50006495Y1338	15660	84	28581	28571*	51958
13.5/8"	13.5/8"	50006795Y1358	32477	84	28581	28571*	51958-1

\* Only door guide required

## VARCO TYPE ELEVATOR/SPIDER 14" 500 TON & FMS375 FLUSH MOUNTED SLIP

### MAIN PART NUMBERS ELEVATOR/SPIDER 14" 500 TON

Part Number	Description
13800Y	Assembly complete, air operated
50006046Y2	Assembly complete, elevator, hydraulic operated*
50006046Y1	Assembly complete, spider, hydraulic operated*
11881	Airline and filter assembly
11798	Guide Bell Assembly, elevator
19276	Spider Adapter Plate

\* Hydraulic type requires HUK



14" E/S 500 ton



FMS 375

### MAIN PART NUMBERS FMS375

Part Number	Description
200930-10	Assembly complete, hydraulically operated, less slips and guides

### OPTIONAL EQUIPMENT PART NUMBERS FMS375

Part Number	Description
50004995	Hinged National 49.1/2" to National 37.1/2"
200990-11	Hinged Oilwell 37.1/2" to National 37.1/2", 6.25" raised load shoulder
200991-11	Hinged Emsco 37.1/2" to National 37.1/2", 6.25" raised load shoulder
200995-11	Hinged National 37.1/2" to National 37.1/2", 6.25" raised load shoulder
201430-1	Hinged Ideco 37.1/2" to National 37.1/2", 6.25" raised load shoulder
200982-1	4 Way Lifting sling for FMS375
50006538	Control panel FMS
50000350	Control panel BX(S) i.c.w. FMS275/FMS375/Hydraulic E/S 14" 500 Ton

## SLIPS, GUIDES & INSERTS 14" 500 TONS ELEVATOR/SPIDER & FMS375

Pipe Size [inches]	Slip Size Nominal [inches]	PARTS			GUIDES			
		Slip Assembly Part Number	Insert Part Number	Quantity	Top Guide Plate Assembly Part Number	ID [inches]	Bottom Guide Plate Assembly Part Number	ID [inches]
4.1/2"	5.1/2"	13842Y3	2168	32 + 16B	V18419-1	5.3/4	11787	5.3/4
5"	"	13842Y2	2169	32 + 16B	V18419-2	6.1/4	11788	6.1/4
5.1/2"	"	13842Y1	2170	48	V18419-3	6.3/4	11789	6.3/4
6.1/4"	"	13841Y62	17080	48 + 24B	18419-62	7.1/2	11789-62	7.1/2
6.5/8"	7.5/8"	13841Y3	2632	48 + 24B	18419-4	8.1/4	11791	8.1/4
7"	"	13841Y2	2623	48 + 24B	18419-4	8.1/4	11791	8.1/4
7.1/2"	"	13841Y74	2669	72	18419-18	9.1/4	11792	9.1/4
7.5/8"	"	13841Y1	2633	72	18419-5	8.7/8	11792	9.1/4
7.3/4"	"	13841Y4	2649	72	18419-5	8.7/8	11792	9.1/4
8.1/8"	"	13841Y81	2633	72	18419-81	9.1/2	11792-81	9.1/2
8.5/8"	9.5/8"	13840Y3	2640	64 + 32B	18419-6	9.7/8	11793	10.1/4
8.3/4"	"	13840Y5	2650	64 + 32B	18419-6	9.7/8	11793	10.1/4
9.5/8"	"	13840Y1	2633	96	18419-7	10.7/8	11794	11.1/4
9.3/4"	"	13840Y4	2649	96	18419-15	11.1/4	71231	11.1/2
9.7/8"	"	13840Y2	2649	96	18419-15	11.1/4	71231	11.1/2
9.7/8"	10.1/8"	94035Y2	2655	96	18419-15	11.1/4	71231	11.1/2
10"	"	94035Y1	2637	96	18419-15	11.1/4	71231	11.1/2
10.1/4"	10.1/8"	94035Y3	2651	96	18419-15	11.1/4	71231	11.1/2
10.3/4"	11.3/4"	13839Y3	2640	80 + 40B	18419-8	12.1/8	11795	12.3/8
10.7/8"	"	13839Y4	2650	80 + 40B	18419-8	12.1/8	11795	12.3/8
11"	"	13839Y5	2638	80 + 40B	18419-112	12.1/8	11795-112	12.3/8
11.3/4"	"	13839Y2	2637	120	18419-9	13.1/8	11796	13.5/16
11.7/8"	"	13839Y1	2651	120	18419-9	13.1/8	11796	13.5/16
12"	12"	94034Y1	2637	120	18419-14	13.1/8	11796	13.5/16
12.3/4"	14"	70734Y7	2657	80 + 40B	18419-13	14.1/4	71229	14.1/2
13.3/8"	"	70734Y5	2636	80 + 40B	18419-10	14.3/4	11797	15
13.1/2"	"	70734Y4	2652	80 + 40B	18419-12	15	71228	15.1/4
13.5/8"	"	70734Y3	2653	80 + 40B	18419-12	15	71228	15.1/4
13.3/4"	"	70734Y2	2655	80 + 40B	18419-12	15	71228	15.1/4
14"	"	70734Y1	2635	120	18419-11	15.375	15939	15.5/8

## VARCO TYPE ELEVATOR/SPIDER 24.1/2" 500 TON



### MAIN PART NUMBERS

Part Number	Description
15740Y	Assembly complete, air operated
50006047Y2	Assembly complete, elevator, hydraulic operated*
50006047Y1	Assembly complete, spider, hydraulic operated*
11881	Airline and filter assembly
19001	Guide Bell Assembly, elevator
16552	Spider Adapter Plate
50000350	Control panel BX(S) i.c.w. FMS275/FMS375/Hydraulic E/S 24.1/2" 500 Ton

\* Hydraulic type requires HUK

### SLIPS, GUIDES & INSERTS 24.1/2" 500 TON ELEVATOR/SPIDER

Pipe Size [inches]	Slip Size Nominal [inches]	PARTS			GUIDES			
		Slip Assembly Part Number	Insert Part Number	Quantity	Spider Top Guide Plate Assembly Part Number	ID [inches]	Elevator Bottom Guide Plate Assembly Part Number	ID [inches]
16"	16"	15790Y4	2635	180	73138	18	16184	18.1/4
17"	17"	15790Y7	2635	180	50006198	19	50006199	19.1/4
18"	18.5/8"	15790Y6	2636	120+60B	73139-6	20	15794-6	20.1/4
18.5/8"	"	15790Y3	2635	180	73137	20.5/8	15794	20.7/8
18.5/8"	20"	15790Y26	17080	120+60B	73137	20.5/8	15794	20.7/8
20"	20"	15790Y2	2635	180	73136	22	15793	22.1/4
22"	22"	15790Y5	2635	180	50006074	24	50006055	24.1/4
24"	24"	15790Y1	2635	180	73135	26	15792	26.1/4
24.1/2"	24.1/2"	75226Y1	2635	180	74817	26.1/2	74818	26.1/4

## VARCO TYPE ELEVATOR/SPIDER 14" 750 TON



### MAIN PART NUMBERS

Part Number	Description
16150Y	Assembly complete, air operated
50006500Y2	Assembly complete, elevator, hydraulic operated*
50006500Y1	Assembly complete, spider, hydraulic operated*
11881	Airline and filter assembly
19002	Guide Bell Assembly, elevator
17163	Spider Adapter Plate
50000350	Control panel BX(S) i.c.w. FMS275/FMS375/Hydraulic E/S 14" 750 Ton

\* Hydraulic type requires HUK

### SLIPS, GUIDES & INSERTS 14" 750 TON ELEVATOR/SPIDER

Pipe Size [inches]	Slip Size Nominal [inches]	PARTS			GUIDES			
		Slip Assembly Part Number	Insert Part Number	Quantity	Spider Top Guide Plate Assembly Part Number	ID [inches]	Elevator Bottom Guide Plate Assembly Part Number	ID [inches]
6.5/8"	7.5/8"	16182Y4	2632	60 + 24B	18419-4	8.1/4	11791	8.1/4
7"		16182Y8	2623	60 + 24B	18419-4	8.1/4	11791	8.1/4
7.5/8"		16182Y7	2633	84	18419-5	8.7/8	11792	9.1/4
7.3/4"		16182Y21	2649	84	18419-5	8.7/8	11792	9.1/4
8.5/8"	9.5/8"	16182Y6	2640	80 + 32B	18419-6	9.7/8	11793	10.1/4
8.3/4"		16182Y20	2650	80 + 32B	18419-6	9.7/8	11793	10.1/4
9.5/8"		16182Y3	2633	112	18419-7	10.7/8	11794	11.1/4
9.3/4"		16182Y19	2649	112	18419-15	11.1/4	71231	11.1/2
9.7/8"		16182Y18	2649	112	18419-15	11.1/4	71231	11.1/2
10.3/4"	11.3/4"	16182Y5	2640	100 + 40B	18419-8	12.1/8	11795	12.3/8
10.7/8"		16182Y17	2650	100 + 40B	18419-8	12.1/8	11795	12.3/8
11.3/4"		16182Y2	2637	140	18419-9	13.1/8	11796	13.5/16
11.7/8"		16182Y16	2651	140	18419-9	13.1/8	11796	13.5/16
13.3/8"	14"	16182Y10	2636	100 + 40B	18419-10	14.3/4	11797	15
13.1/2"		16182Y12	2652	100 + 40B	18419-12	15	71228	15.1/4
13.5/8"		16182Y11	2653	100 + 40B	18419-12	15	71228	15.1/4
13.3/4"		16182Y13	2655	100 + 40B	18419-12	15	71228	15.1/4
14"		16182Y9	2635	140	18419-11	15.3/8	15939	15.5/8

## VARCO TYPE ELEVATOR/SPIDER 24.1/2" 750/1000 TON

### MAIN PART NUMBERS

Part Number	Description
16180Y	750 sTon ass'y complete, air operated
50006600Y1	750 sTon ass'y, spider, complete, hydraulic operated
50006600Y2	750 sTon ass'y, elevator, complete, hydraulic operated
50006265Y1	1000 sTon ass'y, complete, air operated
11881	Airline and filter assembly
19001	Guide Bell Assembly, elevator
16552	Spider Adapter Plate



### SLIPS, GUIDES & INSERTS 24.1/2" 750/1000 TON ELEVATOR/SPIDER

Pipe Size [inches]	Slip Size Nominal [inches]	Slip Assembly Part Number	Insert Part Number	Quantity	Spider Top Guide Plate Assembly Part Number	ID [inches]	Elevator Bottom Guide Plate Assembly Part Number	ID [inches]
8.5/8"	* 9.5/8"	50006535Y858	2640	90+36B	50006533-858	9.7/8	50006532-858	10.1/4
9.5/8"	*	50006535Y958	2633	126	50006533-958	10.7/8	50006532-958	11.1/4
10.1/2"	* 11.3/4"	50006536Y105	2657	126	50006533-1034	12.1/8	50006532-1034	12.3/8
10.3/4"	*	50006536Y1034	2640	90+36B	50006533-1034	12.1/8	50006532-1034	12.3/8
11.3/4"	*	50006536Y1134	2637	126	50006533-1134	13.1/8	50006532-1134	13.5/16
11.7/8"	*	50006536Y1178	2651	126	50006533-1178	13.1/8	50006532-1178	13.5/16
12.3/4"	* 14"	50006537Y1234	2657	120+48B	50006533-11234	14.1/4	50006532-11234	14.1/2
13.3/8"	*	50006537Y1338	2636	120+48B	50006533-1338	11.3/4	50006532-1338	15
13.5/8"	*	50006537Y1358	2653	120+48B	50006533-1358	15	50006532-1358	15.1/4
14"	*	50006537Y140	2635	168	50006533-140	15.3/8	50006532-140	15.5/8
16"	16"	16181Y	2635	210	73138	18	16184	18.1/4
17"	17"	50006194Y	2635	210	50006198	19	50006199	19.1/4
18"	18.5/8"	16381Y2	2636	210	73139-6	20	15794-6	20.1/4
18.5/8"		16381Y1	2635	210	73137	20.5/8	15794	20.7/8
18.5/8"	20"	16179Y	17080	150 + 60B	73137	20.5/8	15794	20.7/8
20"		16178Y	2635	210	73136	22	15793	22.1/4
22"	22"	50006195Y	2635	210	50006074	24	50006055	24.1/4
24"	24"	16900Y	2635	210	73135	26	15792	26.1/4
24.1/2"	24.1/2"	50006196Y	2635	210	74817	26.1/2	74818	26.1/4

\* On request

# POWER SLIPS



## PS21 AND PS30 HYDRAULIC POWER SLIP

### Installs flush with the drill floor

The PS21 and PS30 hydraulic power slips improve both safety and rig efficiency as proven with the FMS Flush Mounted Slip. Proven technology gives optimal performance, high safety operation, allowing to run the whole string with one tool: centralizers, couplings etc, due to enlarged throat opening. Eliminates work platforms for stabbing and operating power tongs during casing running operations.

- Power down slips reacts up to 45,000 (PS21) on 14" casing or 55,000 ft.lbs (PS30) of torque, on 20" casing with sufficient string weight.
- Insert carriers make this a universal tool, not just another power slip
- Allows the PS21 to handle all pipe types and sizes, including BHA's, collars, drill pipe, casing and tubing from 2.3/8" to 14" and PS30 from 2.3/8" to 20"
- Quick changeover from BHA's to collars to drill pipe allows the PS21 and the PS30 to trip the entire string.
- Insert carriers can be changed with pipe in the hole.
- Carrier change can be done in 5 minutes or less.
- Special "drop and lock, pull and release" design eliminates loose pieces such as bolts and pins.
- The PS21 and PS30 can be fitted with insert bowls should it become necessary to use hand slips.
- Reliable slips-set signal
- Corrosion resistant nickel plated manifold blocks
- Integrated pressure relief valve in slip actuators
- Umbilical operations possible (optional guides available)

### Like the insert carriers, the slips also have a rapid change system

- Two handles on the middle slip segment retract and lock the springloaded slip retaining pin.
- No loose parts.

### Centering device

- The PS21 and PS30 are standard equipped with a centering device incorporated in the top cover.
- Ram inserts up to 7.5/8" available in stainless steel (DP only) or mild steel

### Slip set-back designed to pass tool joints, BHAs and casing centralizers

- The slip set back allows tool joints and drill pipe protectors to pass without dragging on the inserts, even when drilling with 6.5/8" drill pipe.
- The PS21/30 will pass: BHA's when tripping; Centralizers when running casing.

### Hook Up Kit

- A control panel, which can be located in the driller's console,
- HUK (Hook Up Kit) with integrated flushing system, greasing pump, pressure switches, dependent on customer requirements, ready for plug and play.

### Control panel

- Stand alone control panels enables the driller to operate the slips. See chapter Power Tools.



## TECHNICAL SPECIFICATIONS

	PS21	PS30
For rotary size	37.1/2"	49.1/2"
Pipe size range	2.3/8" to 14"	2.3/8" to 20"
Load rating	500 sTon	750 sTon
Maximum torque	45,000 ft.lbs	55,000 ft.lbs
Hydraulic requirements	PS21	PS30
Pressure*	2,300 - 2,500 psi	2,300 - 2,500 psi
Flow rate	10 gpm	10 gpm

\* Pressure in return line not to exceed 200 psi.

## MAIN PART NUMBERS

PS21	PS30
202200*	202400*
	202400*-10 (umbilical option)
202200* -BT ( - 40° option)	202400* -BT ( - 40° option)

\* Depending on configuration. Standard delivery includes bit breaker adapter plate, centering device and lifting sling PN 200982-1

## OPTIONAL EQUIPMENT PART NUMBERS

	PS21	PS30
Hand slip bowl # 3: 10.3/4" slip	202361	202361
Hand slip bowl # 3: 16" slip	--	202364
Hand slip bowl # 2: 16" slip	--	202363
Hand slip bowl # 1: 16" slip	--	202362
Hand slip bowl # 3: 10.3/4" removal tool	50004550-21	50004550-21
Hand slip bowl # 1: 16" removal tool	--	50004550-30
Insert carrier removal tool (Pogo stick)	50004600-1	50004600-1
Slip removal tool	50004551	50004551
Slip handle operating tool	50004552	50004552
Extension kit for SD-slip handles	50004604-1	50004604-1
Extension kit for CMS-slip handles	50004604-2	50004604-2
Hatch plate	202458-10	202458
Automated grease unit PS w/RST	50004708	50004708
Grease pump w/ bucket	59000227	59000227

## PS21 SIZE COMPONENTS

Slip Part Number	Clamping diameter [inches]	Pipe type	Zip DC [inches]	Plain DC [inches]	Slip Assy Part Number	Inserts Part Number	Ram Part Number	Throat opening (slips up) [inches]
Inserts directly in slip	14	Csg	--	--	202250-1400	2635	202347-1400	18
	13.5/8	Csg	--	--	202250-1363	2653	202347-1363	17.5/8
	13.1/2	Csg	--	--	202250-1350	2652	202347-1350	17.1/2
	13.3/8	Csg	--	--	202250-1338	2636	202347-1338	17.3/8
	13	Csg	--	--	202250-1300	2640	202347-1300	17
	12.3/4	Csg	--	--	202250-1275	2657	202347-1275	16.3/4
	11.7/8	Csg	--	--	202253-1188	2651	202347-1188	15.7/16
	11.3/4	Csg	--	--	202253-1175	2637	202347-1175	15.5/16
Insert Carrier Part Number						Ram-inserts Part Number		
202250-5	**11.1/8	Csg	--	--	202270-1113	2651	202346-1113	15.3/4
	**11	Csg	--	--	202270-1100	2637	202346-1100	15.1/2
	10.7/8	Csg	--	--	202270-1088	2651	202346-1088	15.1/2
	10.3/4	Csg	--	--	202270-1075	2637	202346-1075	15.3/8
	10	Csg	--	--	202270-1000	2638	202346-1000	14.3/4
	9.7/8	Csg	--	--	202270-988	2650	202346-988	14.9/16
	9.5/8	Csg	--	--	202270-963	2656	202346-963	14.5/16
	9.1/2	Csg	--	--	202270-950	2657	202346-950	14.1/4
	9.1/8	Csg	--	--	202279-913	2637	202346-913	14.1/4
	8.5/8	Csg	--	--	202279-863	2652	202346-863	13.1/2
	7.3/4	Csg	--	--	202279-775	17080	202346-775	13
	7.5/8	Csg	--	--	202273-763	2633	202346-763	12.1/2
	7	Csg	--	--	202273-700	2623	202346-700	11.7/8
	6.7/8	Csg/DP	--	--	202273-688	2638	202346-688	11.3/4
	6.5/8	Csg/DP	--	--	202273-663	2632	202346-663	11.5/8
	6.1/2	Csg	--	--	202369-650	2173	202346-650	11.1/2
	6.9/64	Csg/DP	--	--	202369-614	2172	202346-614	11.1/8
	6	Csg/DP	--	--	202369-600	2169	202346-600	11
	5.7/8	DP	--	--	202369-588	2623	202346-588	11
	5.11/16	Csg/DP	--	--	202369-568	2650	202346-568	10.7/8
	5.1/2	Csg/DP	--	--	202274-550	2170	202346-550	10.3/4
	5	Csg/DP	--	--	202274-500	2169	202346-500	11.1/4
	4.1/2	Tbg/DP	--	--	202274-450	2168	202346-450	9.3/4
	4**	Tbg/DP	--	--	202278-400	2165	202346-400	9.3/8
	9.1/2**	DC	10	9.1/2	202271-950	2633	--	14.3/16
	9.1/4**	DC	9.3/4	9.1/4	202271-925	2655	--	13.15/16
	9	DC	9.1/2	9	202271-900	2633	--	13.11/16
	8.3/4	DC	9.1/4	8.3/4	202271-875	2655	--	13.9/16
	8.5/8	DC	9.1/8	8.5/8	202271-863	2653	--	13.1/2
	8.1/2	DC	9	8.1/2	202271-850	2652	--	13.7/16
	8.1/4	DC	8.3/4	8.1/4	202271-825	2638	--	12.7/8
	8.1/8	DC	8.5/8	8.1/8	202271-813	2650	--	12.3/4
	8	DC	8.1/2	8	202272-800	2633	--	13.1/4
	7.3/4	DC	8.1/4	7.3/4	202272-775	2655	--	13
	7.5/8	DC	8.1/8	7.5/8	202272-763	2172	--	12.1/2
	7.1/2	DC	8	7.1/2	202272-750	2652	--	12.3/4
	7.3/8	DC	7.7/8	7.3/8	202272-738	2636	--	12.1/2
	7.1/4	DC	7.3/4	7.1/4	202272-725	2638	--	12.1/2
	6.3/4**	DC	7.1/4	6.3/4	202275-675	2633	--	11.1/4
	6.1/2	DC	7	6.1/2	202275-650	2633	--	11
	6.1/4	DC	6.3/4	6.1/4	202275-625	2655	--	10.7/8
	6	DC	6-1/2	6	202275-600	2652	--	10.7/8
	5.3/4	DC	6.1/4	5.3/4	202275-575	2638	--	10.5/8
	5.5/8	DC	6.1/8	5.5/8	202275-563	2650	--	10.1/2
	3.1/2	Tbg/DP	--	--	202277-350	2162	202346-350	8.7/8
	3.1/8	Tbg/DP/DC	--	--	202277-313	2172	202346-313	8.7/8
	2.7/8	Tbg/DP	--	--	202277-288	2161	202346-288	8.1/2
	2.3/8	Tbg/DP	--	--	202277-238	2160	202346-238	8.1/8
4.3/4	DC	5.1/4	4.3/4	202276-475	2165	--	10	
4.5/8	DC	--	4.5/8	202276-463	2655	--	9.7/8	
4.3/8	DC	4.3/4	4.3/8	202276-438	2172	--	9.3/4	
4.1/4	DC	--	4.1/4	202276-425	2166	--	9.5/8	
4	DC	--	4	202276-400	2638	--	9.3/8	

\*\* These insert carriers are size specific and cannot be redressed to another size

## PS30 SIZE COMPONENTS

Slip Part Number	Clamping diameter [inches]	Pipe type	Zip DC [inches]	Plain DC [inches]	Slip assy Part Number	Inserts Part Number	Ram Part Number	Throat opening (slips up) [inches]
Inserts directly in slip	20	Csg	--	--	202430-2000	2635	202381-2000	24
	18.5/8	Csg	--	--	202430-1863	17080	202381-1863	22-3/4
	18	Csg	--	--	202430-1800	2635	202381-1800	22
	17.7/8	Csg	--	--	202430-1788	V-2669	202381-1788	21.1/2
Insert Carrier Part Number						Ram-inserts Part Number		
202430-5	16	Csg	--	--	202440-1600	2635	202386-1600	20
	14	Csg	--	--	202441-1400	2635	202386-1400	18
	13.5/8	Csg	--	--	202441-1363	2653	202386-1363	17.5/8
	13.3/8	Csg	--	--	202441-1338	2636	202386-1338	17.3/8
	12.3/4	Csg	--	--	202441-1275	2657	202386-1275	17.1/4
	11.7/8	Csg	--	--	202442-1188	2651	202386-1188	16.7/16
	11.3/4	Csg	--	--	202442-1175	2637	202386-1175	16.5/16
	10.3/4	Csg	--	--	202443-1075	2637	202386-1075	15.3/8
	9.7/8	Csg	--	--	202443-988	2650	202386-988	14.7/16
	9.5/8	Csg	--	--	202443-963	2656	202386-963	14.5/16
	7.5/8	Csg	--	--	202445-763	2633	202386-763	14.1/2
	7	Csg	--	--	202445-700	2623	202386-700	13.7/8
	6.7/8	Csg	--	--	202445-688	2638	202386-688	13.5/16
	6.5/8	Csg/DP	--	--	202445-663	2632	202386-663	13.1/2
	6.1/2	Csg/DP	--	--	50004569-650	2173	202386-650	13.1/4
	5.7/8	DP	--	--	50004569-588	2623	202386-588	13
	5.1/2	Csg/DP	--	--	202446-550	2170	202386-550	10.3/4
	5	Csg/DP	--	--	202446-500	2169	202386-500	10.1/4
	4.1/2	Tbg/DP	--	--	202446-450	2168	202386-450	9.3/4
	** 11.1/8	Csg	--	--	202270-1113	2651	202386-1113	15.3/4
	** 11	Csg	--	--	202270-1100	2637	202386-1100	15.1/2
	10.7/8	Csg	--	--	202270-1088	2651	202386-1088	15.1/2
	10.3/4	Csg	--	--	202270-1075	2637	202386-1075	15.3/8
	10	Csg	--	--	202270-1000	2638	202386-1000	14.3/4
	9.7/8	Csg	--	--	202270-988	2650	202386-988	14.9/16
	9.5/8	Csg	--	--	202270-963	2656	202386-963	14.5/16
	9.1/2	Csg	--	--	202270-950	2657	202386-950	14.1/4
	9.1/8	Csg	--	--	202279-913	2637	202386-913	14.1/4
8.5/8	Csg	--	--	202279-863	2652	202386-863	13.1/2	
7.3/4	Csg	--	--	202279-775	17080	202386-775	13	
7.5/8	Csg	--	--	202273-763	2633	202386-763	12.1/2	
7	Csg	--	--	202273-700	2623	202386-700	11.7/8	
6.7/8	Csg/DP	--	--	202273-688	2638	202386-688	11.3/4	
6.5/8	Csg/DP	--	--	202273-663	2632	202386-663	11.5/8	
6.1/2	Csg	--	--	202369-650	2173	202386-650	11.1/2	
6.9/64	Csg/DP	--	--	202369-614	2172	202386-614	11.1/8	
6	Csg/DP	--	--	202369-600	2169	202386-600	11	
5.7/8	DP	--	--	202369-588	2623	202386-588	11	
5.11/16	Csg/DP	--	--	202369-568	2650	202386-568	10.7/8	
5.1/2	Csg/DP	--	--	202274-550	2170	202386-550	10.3/4	
5	Csg/DP	--	--	202274-500	2169	202386-500	11.1/4	
4.1/2	Tbg/DP	--	--	202274-450	2168	202386-450	9.3/4	
** 4	Tbg/DP	--	--	202278-400	2165	202386-400	9.3/8	

Slip Part Number	Clamping diameter [inches]	Pipe type	Zip DC [inches]	Plain DC [inches]	Slip assy Part Number	Inserts Part Number	Ram Part Number	Throat opening (slips up) [inches]
202433-5	** 9.1/2	DC	10	9-1/2	202271-950	2633	--	14.3/16
	** 9.1/4	DC	9-3/4	9-1/4	202271-925	2655	--	13.15/16
	9	DC	9-1/2	9	202271-900	2633	--	13.11/16
	8.3/4	DC	9-1/4	8-3/4	202271-875	2655	--	13.9/16
	8.5/8	DC	9-1/8	8-5/8	202271-863	2653	--	13.1/2
	8.1/2	DC	9	8-1/2	202271-850	2652	--	13.7/16
	8.1/4	DC	8-3/4	8-1/4	202271-825	2638	--	12.7/8
	8.1/8	DC	8-5/8	8-1/8	202271-813	2650	--	12.3/4
	8	DC	8-1/2	8	202272-800	2633	--	13.1/4
	7.3/4	DC	8-1/4	7-3/4	202272-775	2655	--	13
	7.5/8	DC	8-1/8	7-5/8	202272-763	2172	--	12.1/2
	7.1/2	DC	8	7-1/2	202272-750	2652	--	12.3/4
	7.3/8	DC	7-7/8	7 3/8	202272-738	2636	--	12.1/2
	7.1/4	DC	7-3/4	7-1/4	202272-725	2638	--	12.1/2
	** 6.3/4	DC	7-1/4	6-3/4	202275-675	2633	--	11.1/4
	6.1/2	DC	7	6-1/2	202275-650	2633	--	11
	6.1/4	DC	6-3/4	6-1/4	202275-625	2655	--	10.7/8
	6	DC	6-1/2	6	202275-600	2652	--	10.7/8
	5.3/4	DC	6-1/4	5-3/4	202275-575	2638	--	10.5/8
	5.5/8	DC	6-1/8	5-5/8	202275-563	2650	--	10.1/2
	3.1/2	Tbg/DP	--	--	202277-350	2162	202386-350	8.7/8
	3.1/8	Tbg/DP	--	--	202277-313	2172	202386-313	8.7/8
	2.7/8	Tbg/DP	--	--	202277-288	2161	202386-288	8.1/2
	2.3/8	Tbg/DP	--	--	202277-238	2160	202386-238	8.1/8
	4.3/4	DC	5-1/4	4-3/4	202276-475	2165	--	10
	4.5/8	DC	--	4-5/8	202276-463	2655	--	9.7/8
	4.3/8	DC	4-3/4	4-3/8	202276-438	2172	--	9.3/4
	4.1/4	DC	--	4-1/4	202276-425	2166	--	9.5/8
	4	DC	--	4	202276-400	2638	--	9.3/8

\*\* These insert carriers are size specific and cannot be redressed to another size

## PS15 AND PS16 POWER SLIPS

NOV power slips are designed to eliminate the manual lifting and setting of slips. The PS15 power slip use coil springs as a counterbalance to offset the weight of the slips when in upper, released position. Slips are set by standing on the slipset ring. The foot pedal is pressed to release the slips. The PS16 power slip is an air operated power slip controlled with a foot valve. The slips are set by gravity and released with air pressure much like NOV's casing elevator/spiders.

### PS15 and PS16 power slip features:

- Fits directly into NOV pin drive master bushings.
- Fits 27.1/2" and 37.1/2" to 49.1/2" rotary tables using adapter rings
- Accommodates 3.1/2" to 6.5/8" OD Drill pipe

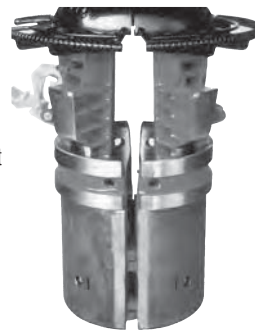

PS15 Spring Slip



PS16 Pneumatic Slip

## TECHNICAL SPECIFICATIONS

	PS15	PS16
For rotary size	27.1/2"	27.1/2"
Drill Pipe size range	3.1/2" to 5.7/8"	3.1/2" to 6.5/8"
Weight {Lbs / kg}	1,040 / 472	1,600 / 727
Load rating	350 sTon	525 sTon
Pressure [Psi / KPa]	n/a	90 / 620

## PS15 AND PS16 MAIN PART NUMBERS & SIZE COMPONENTS

Slip body size [inches]	Drill Pipe Size [inches]	PS15	PS16	Slip set Part Number	Insert set Part Number	Guide ring Part Number
		Complete with Guide and slip set Part Number	Compl. with air controls and hose guide and slip set Part Number			
4.1/2"	3.1/2"	18172-45-35	78181-45-35	7686	2163-16B-32	79011-1
4.1/2"	4	18172-45-40	78181-45-40	7685	2164-16B-32	79011-2
4.1/2"	4.1/2"	18172-45-45	78181-45-45	7684	2165-48	79011-2
5.1/2"	4.1/2"	18172-55-45	78181-55-45	7691	2168-16B-32	79011-2
5.1/2"	5"	18172-55-50	78181-55-50	7690	2169-16B-32	79011-3
5.1/2"	5.1/2"	18172-55-55	78181-55-55	7689	2170-48	79011-4
5.7/8"	5.7/8"	18172-57-57	78181-57-57	7689-57	2173-48	79011-4
*7.5/8"	6.5/8"		78181-76-66	7696	2632-24B-48	7799

\* tripping only!

## OPTIONAL EQUIPMENT PART NUMBERS

Part number	Description
7831	Foot pedal
11814	Connecting hoses (2 required)

## PSF POWER SLIP FRAME & SLT SLIP LIFTING TOOL

### PSF

The Power Slip Frame (PSF) improves drilling and tripping operations with simple, light weight, compact mechanical hydraulic slips. The slips may be operated via the hook up kit. In addition, the slips may be operated manually by foot pedal or hand operated control valve. This product does not wear CE-marking.

### SLT

The Slip Lifter Tool (SLT) is a tool especially designed to be used in combination with the heavy duty MBH1250 hinged master bushing, the LSB1250 Landing String Bushing and LSS1250 Landing String Slips. The SLT operates in combination with the dedicated hook up kit. The SLT also can be used for SDHL-slips using the converting kit. It is CE-marked.

Both tools increase safety by moving personnel away from the hazards at well center during drilling operations. In addition, the design does not extend beyond the rotary table and thereby reduces trip hazards in the event of an accidental rotation of the rotary table. Crew fatigue is minimized by reducing the time and energy required for manual slip operations.

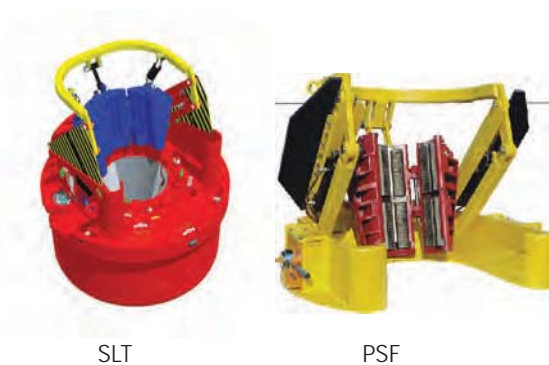

SLT

PSF

## TECHNICAL SPECIFICATIONS

Description	PSF	SLT
Weight w/o slips [lbs / kg]	365 / 166	1,992 / 904
Pipe Size Capacity [inches]	2.3/8" to 7" (with simple adapters required for the range)	5.1/2" to 6.5/8" (LSS) 4.1/2" to 7.5/8" (SDHL)
Control interface	Hook Up Kit or manually by foot pedal or hand operated control valve	Hook Up Kit
Required hydraulic flow [gpm / lpm]	3 / 11.4	5 / 19
Minimum pressure [psi / kPa]	600 / 4,137	2,000 / 13,790
Maximum pressure [psi / kPa]	800 / 5,500	2,500 / 17,235

## MAIN PART NUMBERS

Description	Part number
PSF Power Slip Frame for 20.1/2" pin drive rotary table	1100070-501
PSF Power Slip Frame for 17.1/2" - 27.1/2" square drive rotary table	1100070-502
PSF Power Slip Frame for 27.1/2" & 37.1/2" pin drive rotary table	1100070-503
SLT Slip Lifter Tool	50001400

## OPTIONAL EQUIPMENT PART NUMBERS

Part number	PSF	SLT
50001131	Hook Up Kit	Hook Up Kit
50001450	-	X-over kit for SDHL slips
1100289	Hand valve control kit (open center)	-
1100240	Hand valve control kit (closed center)	-
1100241	Foot valve control kit	-
1100197	Control kit integrated with IR3080	-

## BHAT BOTTOM HOLE ASSEMBLY TOOL

The BHAT Bottom Hole Assembly Tool is a tool designed for easy MU and BO of the bottom hole assembly. It allows the operator to assemble and dis-assemble the bottom hole assembly in a safe way due to built-in safety features.

The maximum rating is 150 sTon / 136 Tonne. The tool has a "no slip" design and will grip all sizes within its range (4" - 6", 6"-10" or 8"-12") without insert/size change. Throat opening 19.5", allowing 17.1/2" BHA to pass. The maximum back-up torque capacity is 50,000 ft.lbs / 67,791 Nm. The minimum required length of any individual clamping surface is 17".

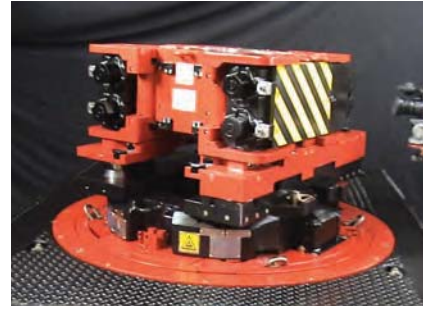

### Features

- The tool has a triple safety built in to prevent dropping objects. First it detects if any pipe is present in the tool. Second it measures if any pressure is set on onto the holding nuts and third it measures if any pressure is applied to the slips.
- A secondary retention system is provided to hold the pipe should the hydraulic power to the tool be lost. A spindle and lock nut design with hydraulic drive motor will provide full mechanical lock. The tool will continue to hold the pipe even with full loss of hydraulic power (once the tool has provided a positive lock signal). If the answer to all these questions is positive, only then the driller receives the signal "open elevator".
- The tool has a "no slip" design and will grip all sizes within its range without insert/size change
- The tool can be placed with an adapter plate on the master bushing and on top of the PS30.
- With adapter plate the tool can be fitted directly into the 37.1/2" rotary table opening, lowering the overall height of the tool.
- The tool uses a dedicated hydraulic system via stand alone control panel OR by using the drillers console.
- The tool is low enough so that a standard iron roughneck can still be driven over the tool to make up the DC connections.

## TECHNICAL SPECIFICATIONS

Description	
Weight, dressed [lbs / kg]	6,666 / 3,000
Pipe Size Capacity [inches]	4" - 6", 6"-10" or 8"-12"
Maximum Load Rating [sTon / Tonne]	150 / 136
Throat opening [inches]	19.5" for 17.1/2" BHA to pass.
Maximum back-up torque capacity [ft.lbs / Nm]	50,000 / 67,791
Minimum required length of clamping surface [inches]	17"
Maximum throat opening [inches]	19.5"
Operating pressure [psi / kPa]	2,000 - 3,500 / 13,789 - 17,236
Operators Control	Electro-hydraulic remote control or manually by foot pedal or hand operated control valve
Seating	PS30 or MPCH pin drive holes and 49.1/2" NATIONAL Rotary Table bore via adapter
Required hydraulic flow [gpm / lpm]	25 / 94

## MAIN PART NUMBERS

Description	Part number
BHAT	50003500Y

## SIZE COMPONENTS

Description	Part number
Self centering carrier 4" - 6"	50003555
Self centering carrier 6" - 10"	50003550
Self centering carrier 8" - 12"	50003554

# BUSHINGS / SLIPS / CLAMPS



## CU, CUL AND CB CASING BUSHINGS

CU, CUL and CB casing bushings are inserted directly into the rotary table and insure that the casing being run is perfectly aligned with the center of the hole. Models CU and CUL are solid bushings and model CB is a split bushing. All of the bushings accept bowls of different sizes to accommodate a wide range of casing. Using CMS-XL or CP-S slips, since these bushings fit into the rotary table, the casing string can be easily rotated during cementing operations.



CU Casing Bushing



CUL Casing Bushing



CB Casing Bushing

Rotary Table Size [inches]	Make	Casing Size [inches]	Casing Bushing and Insert Bowl (P/N)	Weight [lbs/kg]
17.1/2-20.1/2	ALL	11.3/4 and 13.3/8	CU (3102)	470 / 213
		9.5/8 and 10.3/4	W/bowl No. 2 (1902)	342 / 155
26 and 27.1/2	ALL	18.5/8 and 20	CUL (3103)	938 / 425.5
		16	W/bowl 20x16 (3104)	562 / 255
		11.3/4 and 13.3/8	W/bowl No. 1 (3105)	846 / 384
		9.5/8 and 10.3/4	W/bowl No. 2 (1902)	342 / 155
		2.3/8 and 8.5/8	W/bowl No. 3 (1809)	464 / 210.5
27.1/2	ALL	18.5/8 and 20	CB (6695)	713 / 323
		16	W/bowl 20 x 16 (6127)	572 / 259
	NATIONAL	11.3/4 and 13.3/8	W/bowl No. 1 (6126)	895 / 406
		9.5/8 and 10.3/4	W/bowl No. 2 (6114)	252 / 114
		30	CB (V11763)	1100 / 499
37.1/2-49.1/2	OILWELL	26	CB (16454)	1100 / 499
		24	CB (11253)	1200 / 544
		23	CB (11252)	1200 / 544
		18.5/8 and 20	CB (10187)	1600 / 726
		16	W/bowl 20 x 16 (6127)	572 / 259
		11.3/4 and 13.3/8	W/bowl No. 1 (6126)	895 / 406
		9.5/8 and 10.3/4	W/bowl No. 2 (6114)	252 / 114
		30	CB (12093)	1170 / 531
		26	CB (6170-26)	1100 / 500
		24	CB (6170)	1260 / 571.5
37.1/2-49.1/2	EMSCO	18.5/8 and 20	CB (10188)	1670 / 759
		16	W/bowl 20 x16 (6127)	572 / 259
		11.3/4 and 13.3/8	W/bowl No. 1 (6126)	895 / 406
		9.5/8 and 10.3/4	W/bowl No. 2 (6114)	252 / 114
		30	CB (11633)	1160 / 526
		26	CB (89183-1)	1100 / 500
		24	CB (16542)	1260 / 571.5
37.1/2	IDECO	22	CB (11252-22)	1120 / 509
		18.5/8 and 20	CB (11553) S/N 49 and above for 37.1/2 only (10190) S/N 48 and below for 37.1/2 only	1610 / 730
		16	W/bowl 20 x16 (6127)	572 / 259
		11.3/4 and 13.3/8	W/bowl No. 1 (6126)	895 / 406
		9.5/8 and 10.3/4	W/bowl No. 2 (6114)	252 / 114
		30	CB (12092)	1100 / 499
		26	CB (74814-26)	1452 / 605
		24.1/2	CB (74814)	1560 / 650
		18.5/8 and 20	CB ( 10189)	1670 / 759
		16	W/bowl 20 x16 (6127)	572 / 259
37.1/2	IDECO	11.3/4 and 13.3/8	W/bowl No. 1 (6126)	895 / 406
		9.5/8 and 10.3/4	W/bowl No. 2 (6114)	252 / 114

## CASING SPIDERS

The Baash Ross 200 ton hinged casing spider will fit most casing handling operations. It can be placed on the rotary table, mounted on a platform which replaces the rotary table, or supported by cribbing, depending upon the auxiliary equipment and procedure to be followed.

## UC-3 CASING SLIPS

Most casing strings' weight and the relatively thin pipe wall make it important that the supporting slips provide full circumferential grip. The Baash Ross type UC-3 slips achieves this with many narrow segments. They are hinged together to wrap around the casing and exert a more uniform pressure. With each segment carrying the same load, they automatically center the casing string within the bushing or spider. The UC-3 has a 3" taper. With changes in the number of segments and liners, it will handle strings from 16" OD to 42" OD. Liners are held in place by a liner retainer key and cotter pins.



Baash Ross 200 Ton hinged casing spider



UC-3 casing slips

## 200 TON HINGED CASING SPIDERS, INSERT BUSHINGS AND UC-3 SLIPS

Csg. Size	UC-3 Slip No.	Weight [lbs / kg]	30" Spider 7704-A-161	Weight [lbs / kg] 1,200	36" Spider 7704-A-167	Weight [lbs / kg] 1,100	42" Spider 7704-A-179	Weight [lbs / kg] 1,525
16"	7704-5036	226 / 102	Bushing 7704-A-165 Retainers 50012-148-8	975 / 442				
18.5/8"	7704-5035	325 / 147	Bushing 7704-A-164 Retainers 50012-50-8	900 / 408	Bushing 7704-A-172 Retainers 50012-76-8	1135 / 514		
20"	7704-5034	283 / 128	Bushing 7704-A-164 Retainers 50012-50-8	900 / 408	Bushing 7704-A-172 Retainers 50012-76-8	1135 / 514		
22.1/2"	7704-5002	359 / 162	Bushing 7704-A-163 Retainers 50012-38-C8	750 / 340	Bushing 7704-A-171 Retainers 900041-441	924 / 419		
24"	7704-5001	312 / 141	Bushing 7704-A-163 Retainers 50012-38-C8	750 / 340	Bushing 7704-A-171 Retainers 900041-441	924 / 419		
26"	7704-5006	325 / 147	Bushing 7704-A-162 Retainers 50012-26-C8	605 / 274	Bushing 7704-A-170 Retainers 900042-186	817 / 370		
30"	7704-5005	367 / 166	Use 30" Spider		Bushing 7704-A-169 Retainers 50012-32-C8	640 / 290	Bushing 7704-A-180 Retainers 900042-708	1400 / 635
33"	7704-5008	410 / 185			Bushing 7704-A-168 Retainers 50012-20-C8	500 / 226		
36"	7704-5007	437 / 198			Use 36" Spider		Bushing 7704-A-178 Retainers 50012-36-C8	1226 / 556
42" *	7704-5019	495 / 224					Use 42" Spider	

\* 42" Casing spider is rated at 300 sTon / 272 Tonne

## ROLLER KELLY BUSHINGS

### HDP ROLLER KELLY BUSHING

Widely recognized as the standard of the industry. For master bushings with 25.3/4" pin circle 27 HDP of 23" pin circle, 20 HDP. Unit comes with wrench, wiper and wear gauge. Weight 1,500 lbs / 680 kg.

### 27 XHDP ROLLER KELLY BUSHING

For extreme high-torque drilling. Essentially two HDP bushings combined into one unit, this tool reduces wear to kelly and itself through wider force distribution. For master bushings with 25.3/4" pin circle. Unit comes with wrench, wiper and wear gauge. Weight 2,850 lbs / 1,293 kg .

### HDS ROLLER KELLY BUSHING

For heavy duty square drive applications. Components are interchangeable with HDP. Unit comes with wrench, wiper and wear gauge. Weight 1,420 lbs / 644 kg.

### OPTIONAL LOCK ASSEMBLY

Locks for the kelly bushing in the master bushing for use offshore with motion compensators. Lock assembly may be ordered installed in 27-HDP only. To specify, add an "L" to basic part number of unit. Lock assembly alone PN 3695.

Kelly Size	27" HDP	20" HDP	27" XHDP	HDS
Size/Type	Part. No.	Part. No.	Part. No.	Part. No.
3" Hex	3650-30	-	-	-
3.1/2" Hex	3650-35	3690-35	-	3635-35
4.1/4" Hex	3650-42	3690-42	70947-1	3635-42
5" Spec. Hex	3650-50	-	-	-
5.1/4" Hex	3650-52	3690-52	-	3635-52
6" Hex	3650-60	-	70947-2	3635-60
2.1/2" Sq	-	-	-	-
3" Sq	3651-30	-	-	3636-30
3.1/2" Sq	3651-35	3691-35	-	3636-35
4.1/4" Sq	3651-42	3691-42	-	3636-42
5.1/4" Sq	3651-52	3691-52	70947-3	3636-52
6" Sq	3651-60	-	70947-4	-
Less Rollers	3653	3692	70947-BD	3637

### ROLLER ASSEMBLIES COMPLETE

Kelly	HDP*		HDS*	
Size/Type	Part No.	Weight [lbs/kg]	Part No.	Weight [lbs/kg]
3" Sq	3660	590/276	70474-5	176/80
3.1/2" Sq	3661	562/255	70474-6	160/73
4.1/4" Sq	3662	512/232	70474-7	132/60
5.1/4" Sq	3665	438/199	-	-
6" Sq	3666	374/169	-	-
3" Hex	3667	612/278	70474-1	162/74
3.1/2" Hex	3668	584/265	70474-2	146/66
4.1/4" Hex	3669	532/241	70474-3	126/57
4.1/2" Hex	3670	509/230	-	-
5" Sp Hex	3671	486/220	-	-
5.1/4" Hex	3672	476/215	-	-
6" Hex	3673	414/188	-	-

\* Sleeve bearings are standard, roller bearings optional



27" HDP Roller Kelly Bushing

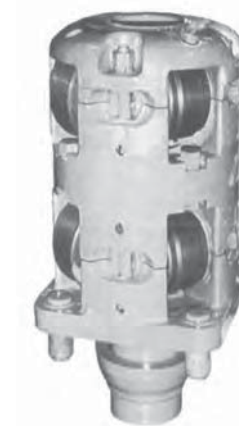

XHDP Roller Kelly Bushing



HDS Roller Kelly Bushing



27.1/2" HDP Roller Kelly Bushing

## KELLY BUSHINGS

### KELLY WIPERS

Kelly Size [inches]	HDP, HDS Square P/N	Weight [lbs/kg]	Hex P/N	Wt [lbs/kg]
3" API	8-0260	4 / 1.8	8-0320	4 / 1.8
3.1/2" API	8-0265	4 / 1.8	8-0285	4 / 1.8
4.1/4" API	8-0170	3.5 / 1.6	8-0275	3.5 / 1.6
5.1/2" API	8-0300	3 / 1.4	8-0305	3 / 1.4
6" API	8-0200	3 / 1.4	8-0240	3 / 1.4

### KELLY BUSHING SAFETY GUARD

Fits Rotary Tables with HDP-HDS Kelly Bushings.

For 17.1/2" - 27.1/2" Rotary Table P/N 15794

For 37.1/2" Rotary Table P/N 16951

For 49.1/2" Rotary Table P/N 16953

## MPCH MASTER BUSHING

The 37.1/2" MPCH pin drive hinged master bushing is specially designed for floating and semi-submersible drilling operations.

With insert bowl No. 3 and optional insert bowls No. 1 and No. 2, the MPCH master bushing will handle 2.3/8" to 13.3/8" OD drill collars, tubing and casing.

Unit comes complete with No. 3 insert bowl, bit breaker adapter plate and 4 way lifting sling PN 6699.

Part	P/N	Weight [lbs/kg]
Complete	*	4200 / 1905
Body only	*	3200 / 1452
Insert Bowl No. 1: 13.3/8" to 11.3/4"	6610	336 / 152
Insert Bowl No. 2: 10.3/4" to 9.5/8"	6609	470 / 213
Insert Bowl No. 3: API 8.5/8" and smaller	6608	625 / 283
2 way lifting sling for insert bowls	1021	46 / 22

\* See selection chart

## MSPC MASTER BUSHING

The 27.1/2" MSPC solid body pin drive master bushing designed for all drilling operations. The pin drive allows the Kelly bushing to ride on top of the rotary table and permits extended bowls to be used for better slip back up. With the extended API insert bowl No. 3, the MSPC master bushing will handle 2.3/8" thru 8.5/8" OD drill pipe, drill collars, tubing and casing. Insert bowl No. 2 can handle tubulars from 9.5/8" to 10.3/4" OD; while insert bowl No. 1 is good for 11.3/4" to 13.3/8" OD. Unit comes with No. 3 insert bowl, bit breaker adapter plate and 4 way lifting sling PN 6699.

Part	P/N	Weight [lbs/kg]
27.1/2" complete	*	1965 / 891
body only	*	1110 / 503
Insert Bowl No.1: 13.3/8" and 11.3/4"	1903	326 / 148
Insert Bowl No.2: 10.3/4" and 9.5/8"	1904	460 / 209
Insert Bowl No.3: API 8.5/8" and smaller	1810	620 / 281
2 way lifting sling for insert bowls	1021	46 / 22

\* See selection chart

## MSP MASTER BUSHINGS

### MSP 27.1/2" split pin drive bushings\*

MSP 27.1/2" split pin drive bushings are also available. With the larger rotary opening the standard No. 3 extended API taper is used. This allows the use of extra-long SDXL slips required for heavier loads. Weight 1600 lbs / 726 kg.

\* See selection chart



MPCH with # 3 bowl and SDXL slips



MPCH with bit breaker adapter plate



MSPC



MSP

## MASTER BUSHING SELECTION CHART

Make	Type	MPCH		MSPC		MSP	
		Compl.	Body only	Compl.	Body only	Compl.	Body only
Emsco	T-2750	-	-	1804-1	1808-1	5429-1	-
	G-27.1/2	-	-	1804-5	1808-5	5429-5	-
	H-27.1/2	-	-	1804-2	1808-2	-	-
	K-27.1/2, KS, P1	-	-	1804-3	1808-3	-	-
	T-3750 (S/N 1-48)	6600-2A	6601-2A	-	-	-	-
	T-3750/T-4950 (49/UP)	6600-2	6601-2	-	-	-	-
Ideco	27.1/2	-	-	1804-7	1808-7	5429-7	-
	37.1/2	6600-4	6601-4	-	-	-	-
National	MS-27 .1/2, A and B-27.1/2	-	-	1804-5	1808-5	5429-5	-
	C-365	6600-5	-	-	-	-	-
	C-375	6600-1	6601-1	-	-	-	-
Oilwell	27 .1/2, 27.1/2 A	-	-	1804-9	1808-9	-	-
	A-27.1/2	-	-	1804-1	1808-1	5429-1	-
	A-37.1/2	6600-3	6601-3	-	-	-	-
Wirth*	27.1/2	-	-	1804-1	1808-1	5429-1	-
	37.1/2	6600-6	6601-6	-	-	-	-

\*WIRTH is a trademark of Wirth Maschinen- und Bohrgeräte-Fabrik GmbH. The Wirth trademark and trade name referenced above are used solely for reference purposes and NOV is not affiliated with Wirth and Wirth does not endorse any of NOV's products.

## MBH1250 HINGED MASTER BUSHING

For the safe handling of heavy weight casing strings, including bit, in combination with the corresponding landing strings, a new series of rotary equipment, having a dedicated rating and safety factor, has been developed.

- Casing sizes up to 24", for string weights up to 750 sTon.
- 5.1/2" to 6.5/8" landing strings with dedicated drill pipe, string weights up to 1,250 sTon.
- Dual upset drill pipe, string weight up to 1,250 sTon.
- All standard pipe types and sizes with special #1, #2 and #3 master bushing bowls, string weights up to 750 sTon.
- Standard bit breaker plates. Maximum bit diameter 29.1/2".

### CASING BUSHINGS

Height and internal diameters/tapers of casing bushing are 100% identical to standard NOV Varco BJ 24" CB16542 casing bushing. Interfaces with standard 24" CMS-XL casing slips.

### DRILLING BOWLS

Interfaces with standard API handslips featuring a 1: 6 taper.

When removed from the MBH1250 bushing, a 29.1/2" diameter bit can pass through MBH1250, without the need to remove the MBH1250 from the rotary table, due to throat opening of 30". These bowls feature the standard MPCH bit breaker holes. Standard bit breaker plates, kelly bushings, etc, fit into these holes. Interfaces with same torque backup blocks in the MBH1250 as above mentioned casing bowls for torque backup an assembly.

### LSB1250 LANDING STRING BUSHING

To handle 1,000 sTon capacity landing strings, the MBH1250 can be dressed with the LSB1000 landing string bowl. Combined with the special design landing string hand slips, the landing string can be run up to loads of 1,000 sTon. The landing string slips grip the pipe with standard inserts. Customers should always perform a crushing load calculation to determine the ultimate safe working load of the system.

To handle 1,250 sTon capacity landing strings, the MBH1250 can be dressed with the LSB1250 landing string bowl. Combined with the special design landing string hand slips, the landing string can be run up to loads of 1,250 sTon. The 1,250 sTon capacity can only be achieved with landing strings with "dual upset" connections, i.e. the joint has two 18 degree tool joints. A 1,250 sTon capacity BX style elevator will be connected to the upper tool joint, while the lower tool joint is suspended in the LSB1250 with the special slips that have an 14 degree contour in the slips, rather than inserts.

## TECHNICAL SPECIFICATIONS

Description	Size
Size	Fits into 49.1/2" National rotary table (= 49.1/2" RST) as standard.
Height	20" (equal to a standard 37.1/2" MPCH Master Bushing)
Internal throat opening	30"
Maximum backup torque	500,000 ft.lbs / 677,910 Nm
Load Rating axial	1,250 sTon / 1,134 Tonne
Load Rating axial w/ spreading load 1:6 taper	1,000 sTon / 907 Tonne
Lifting slings	Can be handled (lifted) with standard lifting slings with certified latching hooks or standard certified shackles.



MBH1250 with drilling bowl and slips



MBH1250 with casing bushing



MBH1250 with drilling bowl



MBH1250 with LSB1250 landing string bushing and LSS1250 landing string slip



LSS1250 landing string slip

## MAIN PART NUMBERS

### MBH1250 MASTER BUSHING HINGED

Part number	Name
50005900-2	MBH1250 Emsco
50005900-3	MBH1250 National
50005900-4	MBH1250 Oilwell
50005900-6	MBH1250 Wirth**
50005900-7	MBH1250 Ideco

### MBH1250 MASTER BUSHING HINGED W/ BOWL #3, + BIT BREAKER PLATE + LIFTING SLING

Part number	Name
50005900-200	MBH1250 Emsco
50005900-300	MBH1250 National
50005900-400	MBH1250 Oilwell
50005900-600	MBH1250 Wirth**
50005900-700	MBH1250 Ideco

### CASING BUSHINGS

Part number	Description
50005905	Casing bushing for 24"
50005906	Casing bushing for 22"
50005907	Casing bushing for 20"
50005908	Casing bushing for 16"

### DRILLING BOWLS

Part number	Description
50005910-1	MBH bowl #1 - 11.3/4" - 13.3/8"
50005911-1	MBH bowl #2 - 8.5/8" - 10.3/4"
50005912-1	MBH bowl #3 - 2.3/8" - 8.5/8"

\* only to be used with standard hand Slips (SDML, SDS, SDXL, SDHL, CMS, DCS)

### LSB1250 - LANDING STRING BUSHING

Part number	Description
50005920-1	Landing String Bushing 1250 sTon load rating

### LSS1250 LANDING STRING SLIPS

Type	Size [inches]	Part number	Insert	Qty	Weight [lbs/kg]
LSS750*	5,1/2	50005925-1	50003937	60	640 / 290
LSS1250	5.7/8	50005929-1	50003937	60	620 / 281
LSS1250	6.5/8	50005935-1	50003937	60	581 / 263
LSS1250	6.906	50005939-1	50003937	60	565 / 256
LSS1250	7.5/8"	50005945-1	50003937	60	545 / 247

\* higher rating impossible due to limitations of massive CMS-01 test mandrel which will break at higher ratings

\*\*WIRTH is a trademark of Wirth Maschinen- und Bohrgeräte-Fabrik GmbH. The Wirth trademark and trade name referenced above are used solely for reference purposes and NOV is not affiliated with Wirth and Wirth does not endorse any of NOV's products.

## LIFTING SLINGS

Suitable for the MBH1250 master bushing, casing bushings and the MBH-bowls. Allowed for overhead lifting purposes.

### MAIN PART NUMBERS

Name	Part number	CE	DnV
4 Way Lifting Sling Chain Design	50001110	Yes	Yes
2 Way Lifting Sling Chain Design	50001120	Yes	Yes
4 Way Lifting Sling Cable Design	50001140	Yes	Yes
2 Way Lifting Sling Cable Design	50001150	Yes	Yes



## LIFTING SLINGS

Suitable for the MPCH, MSPC & MSP master bushing & bowls. Not allowed for overhead lifting purposes.

### MAIN PART NUMBERS

Name	Suitable as	Part number	CE	DnV
2 Way Lifting Sling Chain Design	Bowl lifter	50001130	Yes	Yes
2 Way Lifting Sling Cable Design	Bowl lifter	50001160	Yes	Yes
2 way Lifting Sling	Bowl lifter	1021	No	No
4 way Lifting Sling	Master Bushing lifter	6699	No	No

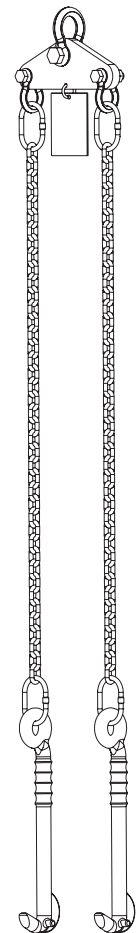



## ROTARY SLIPS, CASING SLIPS

### SDS, SDML, SDXL and SDHL rotary slips

SDS, SDML, SDXL and SDHL rotary slips are for use in API standard insert bowls. Featuring better contact and distribution of load on drill pipe through a superior wraparound configuration and unique insert design, these slips prevent bottle necking and gouging damage. The buttress design of the body segments provides great strength while minimizing weight for ease of handling.

**⚠️ WARNING: SDXL type hand slips are not to be used on floating drilling vessels / installations. Use SDHL type hand slips instead.**

### Rotary slips complete\*

Slip Size [inches]	API Pipe Sizes OD [inches]	SDS P/N	SDML P/N	SDXL P/N	SDHL 750 ton P/N	
3.1/2	2.3/8	3901	15524	-	-	
	2.7/8	3903	15523	-	-	
	3.1/2	3905	15522	-	-	
4.1/2	3.1/2	3907	15563	V15515	-	
	4	3909	15564	15514	-	
	4.1/2	3911	15565	V15513	-	
5	4	-	15567	15518	-	
	4.1/2	-	15568	15517	-	
	5	-	15569	V15516	-	
5.1/2**	4.1/2	-	15571	15521	50006021-450	
	5	-	15572	15520	50006021-500	
	5.1/2	-	15573	V15519	50006021-550	
6.7/8**	5.5/8	-	-	-	50006040-563	
	5.3/4	-	-	-	50006040-575	
	5.7/8	-	-	-	50006040-588	
	6	-	-	-	50006040-600	
	6.3/8	-	-	-	50006040-638	
	6.5/8	-	-	-	50006040-663	
	6.7/8	-	-	-	50006040-688	
	7	6.5/8	-	-	86720	-
	7	7	-	-	86719	-

\*\* Load rings for SDHL

Slip size	Load ring part number	Cotter pin part number
5.1/2	50006033	51403-12-S
6.7/8	50006038	51403-12-S



SDXL SLIP

### CMS-XL extra long multi-segment casing slips

Today's deeper drilling calls for long and heavy casing strings. NOV has slips to handle any casing job.

Varco CMS-XL slips are manufactured from castings, reinforced to take severe service. The self-centering full wraparound grip prevents damage to casing. With certain simple adjustments, the CMS-XL can accommodate casing from 6.5/8" to 30" OD. All NOV slips have an API taper of 4"/ft on the diameter.

### DCS drill collar slips

Each slip segments are castings with an extra long back to provide maximum support to the circular button gripping elements. Full wraparound design and circular buttons assure positive holding and slip setting. Drill collar slips are flat on top to accommodate the MP clamp. All NOV slips have an API taper of 4"/ft on the diameter.

### CMS-XL casings slips and cp-s conductor pipe slips

Slip Set	Casing OD [inches]	P/N	Slip Set	Drill Collar OD [inches]	P/N
CMS-XL	6.5/8	5315	DCS-S	3 - 4	2572
	7	5301		4 - 4.7/8	2573
	7.5/8	5303	DCS-R	4.1/2 - 6	2552
	8.5/8	5305		5.1/2 - 7	2550
	9.5/8	5307	DCS-L	5.1/2 - 7	2501
	10.3/4	V5309		6.3/4 - 8.1/4	2503
	11.3/4	5311		8 - 9.1/2	2507
	13.3/8	5313		8.1/2 - 10	2530
	16	5325		9.1/4 - 11.1/4	2508
	18	5335-1		11 - 12.3/4	2534
18.5/8	5333	12 - 14	V2536		
20	5329	CP-S			
24	5331		24	5338	
26	5346		26	5344	
30	5342		30	5340	



CMS-XL SLIP

## CIRCULAR BUTTONS

### CIRCULAR BUTTONS FOR CMS-XL AND CP-S

Slip Set	Casing OD [inches]	Circular Buttons			
		Part No.	Weight lbs	kg	Qty
CMS-XL	6.5/8	2628-144	36	16	144
	7	2619-144	36	16	144
	7.5/8	2630-144	24	11	144
	8.5/8	2630-156	26	12	156
	9.5/8	2630-168	28	13	168
	10.3/4	2630-180	30	14	180
	11.3/4	2627-204	51	23	204
	13.3/8	2630-216	36	16	216
	16	2631-252	43	19.5	252
	18.5/8	2626-300	60	27	300
	20	2631-312	52	23.3	312
	24	2631-360	60	27	360
	26	2631-396	64	29	396
	30	2631-444	72	32.5	444

### CIRCULAR BUTTONS FOR DCS SLIPS

Slip Set	Drill Collar OD [inches]	Circular buttons			
		Part No.	Weight lbs	kg	Qty
CP-S	24	2631-156	26	12	156
	26	2631-168	28	13	168
	30	2631-192	32	14.5	192
DCS-S	3 - 4	2628-49	13	6	49
	4 - 4.7/8	2620-49	8	3.5	49
DCS-R	4.1/2 - 6	2628-63	16	7	63
	5.1/2 - 7	2620-63	11	5	63
DCS-L	5.1/2 - 7	2513-88	22	10	88
	6.3/4 - 8.1/4	2630-88	15	7	88
	8 - 9.1/2	2630-96	16	7	96
	8.1/2 - 10	2627-104	26	12	104
	9.1/4 - 11.1/4	2630-112	19	8.5	112
	11 - 12.3/4	2625-136	13	6	136
	12 - 14	2630-136	16	7	136

### SDS SHORT ROTARY SLIPS AND SDS INSERTS

Slip Body Size [inches]	3.1/2"				4.1/2"	
Pipe Size [inches]	2.3/8	2.7/8	3.1/2	3.1/2	4	4.1/2
P/N Slip w/inserts	3901	3903	3905	3907	3909	3911
Weight Slip w/insert [lbs / kg]	134 / 61	128 / 58	124 / 56	162 / 73	155 / 70	146 / 66
Insert Set: part number	2160-24	2161-24	2162-24	2163-36	2164-36	2165-36
Insert Set [Qty]	24	24	24	36	36	36

### SDML MEDIUM ROTARY SLIPS AND SDML INSERTS

Slip Body Size [inches]	3.1/2"	3.1/2"	3.1/2"	4.1/2"	4.1/2"	4.1/2"	5"	5"	5"	5"	5.1/2"	5.1/2"	5.1/2"
Pipe Sizes [inches]	2.3/8	2.7/8	3.1/2	3.1/2	4	4.1/2	4	4.1/2	5	4.1/2	5	5.1/2	5.1/2
P/N Slip w/inserts	15524	15523	15522	15563	15564	15565	15567	15568	15569	15571	15572	15573	15573
Weight : Slip w/inserts [lbs / kg]	193 / 87.5	188 / 85	180 / 81.50	207 / 94	199 / 90	188 / 85	204 / 92.5	196 / 89	185 / 84	200 / 91	192 / 87	181 / 82	181 / 82
P/N Insert set	2160-30	2161-30	2162-30	2163-45	2164-45	2165-45	2168-45	2166-45	2167-45	2168-45	2169-45	2170-45	2170-45
Insert set: Qty	30	30	30	45	45	45	45	45	45	45	45	45	45

### SDXL EXTRA LONG ROTARY SLIPS AND INSERTS

Slip Body Size [inches]	4.1/2"				5"		
Pipe Sizes [inches]	3.1/2	4	4.1/2	4	4.1/2	5	4.1/2
P/N Slip w/inserts	V15515	15514	V15513	15518	15517	V15516	15521
Weight : Slip w/inserts [lbs/kg]	229 / 104	219 / 99	205 / 93	237 / 107.5	227 / 103	213 / 96.5	234 / 106
Insert set part number	2163- 54	2164- 54	2165- 54	2168- 54	2166- 54	2167- 54	2168- 54
Inserts [Qty]	54	54	54	54	54	54	54
Slip Body Size [inches]	5.1/2"		7"				
Pipe Sizes [inches]	5	5.1/2	5.3/4	5.7/8	6	6.5/8	7
P/N Slip w/inserts	15520	V15519	86719-1	86722-1	86719-2	86720	86719
Weight : Slip w/inserts [lbs/kg]	224 / 101.5	210 / 95	242 / 110	232 / 105	220 / 100	200 / 91	190 / 110
Insert set part number	2169- 54	2170 - 54	2521	2656	2632-60	2172- 60	2173-60
Inserts [Qty]	54	54	60	60	48	60	60

**SDHL ROTARY SLIPS AND INSERTS**

Slip Body Size [inches]	5.1/2"			6.7/8"	
Pipe Sizes [inches]	4.1/2	5	5.1/2	5.5/8"	5.3/4"
P/N Slip w/inserts	50006021-450	50006021-500	50006021-550	50006040-563	50006040-575
Weight : Slip w/inserts [lbs/kg]	*	250 / 113	235 / 107	260 / 117	250 / 113
Insert set part number	2168	2169	2170	2521	2656
Inserts [Qty]	45	45	45	60	60
Slip Body Size [inches]	6.7/8				
Pipe Sizes [inches]	5.7/8	6	6.3/8	6.5/8	6.7/8
P/N Slip w/inserts	50006040-588	50006040-600	50006040-638	50006040-663	50006040-688
Weight : Slip w/inserts [lbs/kg]	235 / 107	230 / 104	220 / 100	210 / 95	200 / 91
Insert set part number	2632	2650	2652	2655	2173
Inserts [Qty]	60	60	60	60	60

**FLEX HANDLES**

Available for all Varco BJ rotary hand slips (SDS, SDML, SDXL and SDHL).  
 Can be assembled on rotary hand slips without any modification.  
 Protection horn on top of the handle provides guard to crew hands, should elevator be lowered too much.  
 The elastomer section allows the handle to bend. Handle will recover to its original shape.  
 Reduces bend and broken handles. Bent handles do not give crew hands an ergonomically lifting position.



**SLIPS WITH FLEX HANDLES**

Slip size [inches]	Pipe size [inches]	SDS P/N	SDML P/N	SDXL P/N	SDHL P/N
3.1/2	2.3/8	3901-FH	15524-FH		
	2.7/8	3903-FH	15523-FH		
	3.1/2	3905-FH	15522-FH		
4.1/2	3.1/2	3907-FH	15563-FH	V15515-FH	
	4	3909-FH	15564-FH	15514-FH	
	4.1/2	3911-FH	15565-FH	V15513-FH	
5	4		15567-FH	15518-FH	
	4.1/2		15568-FH	15517-FH	
	5		15569-FH	V15516-FH	
5.1/2	4.1/2		15571-FH	15521-FH	50006021-450-FH
	5		15572-FH	15520-FH	50006021-500-FH
	5.1/2		15573-FH	V15519-FH	50006021-550-FH
6.7/8	5.5/8				50006040-563-FH
	5.7/8				50006040-588-FH
	6.5/8				50006040-663-FH
	6.7/8				50006040-688-FH
7	6.5/8			86720-FH	
	7			86719-FH	

Note: eliminate -FH when ordering slips with regular handles

## MULTIPURPOSE SAFETY CLAMP

Safety clamps are a convenient way to secure flush tubular products during installation. The MP clamp can act as the last resort, when a piece of tubular slips through the slips. Especially in combination with handslips, the clamp will land on top of the slips, adding extra push down force to the slips and thus stopping the tubular from slipping through the slip.

**⚠️ WARNING: The MP clamps should NOT be used for snubbing or lifting operations.**



MP Safety Clamp

### MP SAFETY CLAMP

Range [inches]	P/N Clamp Cplt.	P/N Links	Qty Links	P/N Grip Die	Qty Grip Dies
<b>MP-S</b>					
2.7/8 - 4.1/8	33030	3335	7	3333	8
4 - 5	33031	3335	8	3333	9
<b>MPR</b>					
4.1/2 - 5.5/8	33011	3319	7	3310	8
5.1/2 - 7	33012	3319	8	3310	9
6.3/4 - 8.1/4	V33013	3319	9	3310	10
8 - 9.1/4	V33014	3319	10	3310	11
9.1/4 - 10.1/2	33015	3319	11	3310	12
<b>MP-M</b>					
10.1/2 - 11.1/2	33016	3319	12	3310	13
11.1/2 - 12.1/2	33017	3319	13	3310	14
12.1/2 - 13.5/8	33018	3319	14	3310	15
13.5/8 - 14.3/4	33019	3319	15	3310	16
14.3/4 - 15.7/8	33020	3319	16	3310	17
<b>MP-L</b>					
15.7/8 - 17	33021	3319	17	3310	18
17 - 18.1/2	33022	3319	18	3310	19
18.1/8 - 19.3/8	33023	3319	19	3310	20
<b>MP-XL</b>					
19.3/8 - 20.3/8	33024	3319	19	3310	20
20.3/8 - 21.1/2	33025	3319	20	3310	21
21 - 22.5/8	V33032	3319	21	3310	22
22.5/8 - 23.3/4	V33033	3319	22	3310	23
23.3/4 - 24.7/8	33034	3319	23	3310	24
24.7/8 - 26	V33035	3319	24	3310	25
26 - 27.1/8	33036	3319	25	3310	26
29.3/8 - 30.1/2	V33039	3319	28	3310	29



# MANUAL TONGS

## MANUAL TONGS

The HT tong is a tool designed for making up and breaking connections of tubular goods, from light tubing to heavy wall pipe and drill collars. There are 7 types, varying in torque capacity from 10,000 to 200,000 lbs / ft (13,560 - 271,000Nm). Covered sizes from 2 3/8" to 17", or 36" (HT50 with extended reach).

Interchangeable lug jaw design permits each tong to handle different sizes of pipe. By installing hinge jaws (available for some models), bigger pipe sizes can be handled.

The tongs can be assembled for either making-up or break-out by removing the hanger and turning the complete HT tong over.

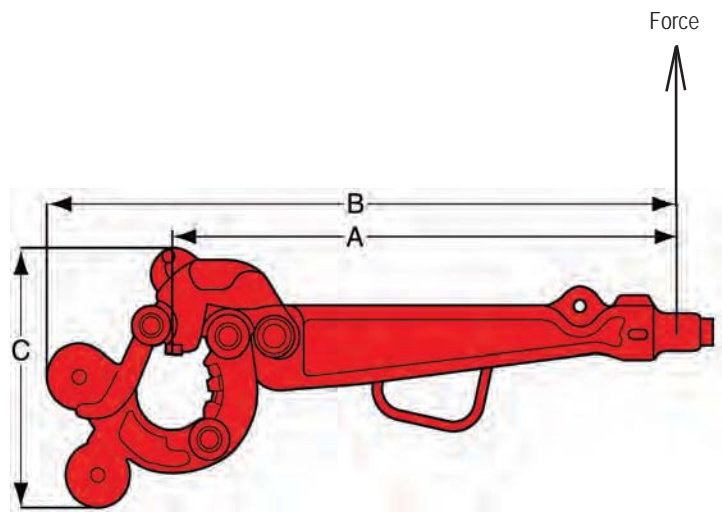

## DIMENSIONS

HT tong type	Size range lever [inches]	Size range lever [mm]	A max. type	A min. [inches]	A [mm]	B max. [inches]	B [mm]	B min. [inches]	B [mm]	C [inches]	C [mm]		
14	2.3/8 - 7	60.3 - 177.8	Standard	27	685	24.3/4	628	33	838	30.3/4	181	355	
35	2.3/8 - 10.3/4	60.3 - 273.1	Long lever	47.1/8	1196	44.5/8	1133	57.1/8	1450	54.5/8	1387	457	
			Short lever	36.3/16	919	33.11/16	885	46.11/16	1173	43.11/16	1109	18	457
55	3.1/2 - 13.3/8	88.9 - 339.7	Long lever	55.3/16	1401	52.1/16	1322	66.7/16	1687	59.9/16	1512	23.1/4	590
			Short lever	49.3/16	1249	46.1/16	1169	60.7/16	1535	53.9/16	1360	23.1/4	590
65	3.1/2 - 17	88.9 - 431.8	Standard	59.9/16	1436	50.15/16	1293	72.9/16	1843	72.9/16	1519	35.3/4	908
100	4 - 17	101.6 - 431.8	Standard	60	1524	53.7/8	1368	78	1981	78	1641	34.1/8	866
	7.1/2 - 12	190.5 - 304.8	Standard	62.1/2	1597	60	1524	80	2032	76.3/8	1940	31.3/4	806
200	6 - 16	203.2 - 406	Standard	62.3/8	1584	57.11/16	1465	78	1981	68	1727	38	965

### Casing head assembly only

HT tong type	Size range lever [inches]	Size range lever [mm]	
HT50	13.3/8 - 36	339.7 - 914.4	Lever to be used with HT55 tong and hanger

## MAIN PART NUMBERS AND SIZE EQUIPMENT TONGS

Part Description	Part no.	Torque Rating		Weight	
		[ft.lbs]	[Nm]	[lbs]	[kg]
<b>HT14</b>					
Complete less lug jaws	200640	-	-	99	45
Lug jaw assembly 2.3/8"-3.1/2"	200645-1	10,000	13,558	12	5.4
Lug jaw assembly 3.1/2"-5"	200646-1	10,000	13,558	15	6.8
Lug jaw assembly 4.3/4"-6.1/4"	200647-1	14,000	18,981	24	10.9
Lug jaw assembly 5.3/4"-7"	200648-1	12,000	16,269	31	14
<b>HT35</b>					
Long lever 7" x 10.3/4" less lug jaw	200620	-	-	242	110
Short lever 7.5/8" x 10.3/4" less lug jaw	200620-1	-	-	238	108
Long lever 2.3/8" x 7" less lug jaw	200620-2	-	-	242	110
Short lever 2.3/8" x 7" less lug jaw	200620-3	-	-	238	108
Lug jaw assy. 2.3/8" - 3.668"	200076-1	15,000	20337	25	11
Lug jaw assembly 2.7/8" - 4.1/4"	200077-1	15,000	20337	29	13
Lug jaw assembly 3.1/2" - 5.1/4"	200078-1	25,300	34,302	33	15
Lug jaw assembly 5.1/4" - 7"	200079-1	33,500	45,419	45	20
Hinge and lug jaw assembly 7" - 8.5/8"	200080-2	25,000	33895	33	15
Hinge and lug jaw assembly 9.5/8" - 10.3/4"	200081-2	32,000	43386	76	34.5
<b>HT55</b>					
Complete with long lever, less lug jaws	200560	-	-	400	181
Complete with short lever, less lug jaws	200560-1	-	-	386	175
Lug jaw assembly 3.1/2"-5"	200083-1	35,000	47,453	29	13
Lug jaw assembly 5"-6.3/4"	200084-1	55,000	74,570	39	17.7
Lug jaw assembly 6.5/8"-9"	200085-1	55,000	74,570	56	25.4
Lug jaw assembly 9"-10.3/4"	200086-1	40,000	54,232	60	27.2
Lug jaw assembly 11.3/4"	200087-1	30,000	40,674	61	27.7
Lug jaw assembly 12"	200088-1	30,000	40,674	65	29.5
Lug jaw assembly 12.3/4"-13"	200089-1	30,000	40,674	72	32.7
Lug jaw assembly 13.3/8"	200090-1	30,000	40,674	72	32.7
<b>HT65</b>					
Complete less lug jaws	200540	-	-	440	199.6
Lug jaw assembly 3.1/2"-8.1/4"	200546-1	65,000	88,128	82	37.2
Lug jaw assembly 8"-11.1/4"	200547-1	65,000	88,128	97	44
Lug jaw assy. 11.3/4"-14.3/8"	200548-1	40,000	54,232	71	32
Lug jaw assembly 16"-17"	200549-1	40,000	54,232	83	37.6
Hinge jaw assembly 8"-17"	200545-1	40,000	54,232	56	25.4
<b>HT100</b>					
Complete less lug jaws	200071	-	-	533	241
Lug jaw assembly 4" - 8.1/2"	200663-1	100,000	135,582	135	61
Lug jaw 8.1/2" - 12"	200664	100,000	135,582	102	46.3
Lug jaw 12" - 15"	200665	75,000	101,686	140	63.5
Lug jaw 15.3/4"	200666	60,000	81,349	162	73.5
Lug jaw 16" - 17"	200667	60,000	81,349	135	61.2
Hinge jaw assy. 8.1/2" - 17"	200662-1	60,000	81,349	112	50.8
<b>HT200</b>					
Complete less lug jaws	200500	-	-	1050	476
Lug jaw 6" - 7.7/8"	200506-SP	200,000	271,164	90	40
Lug jaw assembly 8" - 9.5/8" or 13" - 13.1/4"	200506-1	200,000	271,164	89	40.4
Lug jaw assy. 9" - 11.1/8" or 13" - 14.3/4"	200507-1	175,000	237,268	104	47.2
Lug jaw assembly 11"-12.1/2" or 14.3/8" - 16"	200508-1	200,000	271,164	150	68
Hinge jaw assy. 11.1/2" - 16"	200505-1	150,000	203,373	60	27.2



## MAIN PART NUMBERS CASING HEAD ASSEMBLIES

Range [inches]	Casing head assy Part no	Torque rating		Weight	
		[ft.lbs]	[Nm]	[lbs]	[kg]
13.3/8" - 14.1/2"	200580-1	50,000	67,791	340	154
14.1/2" - 16"	200580-2	50,000	67,791	352	159
16" - 17.1/2"	200580-3	50,000	67,791	373	169
17.1/2" - 19"	200580-4	50,000	67,791	385	175
19" - 20"	200580-5	50,000	67,791	397	180
20" - 21.1/2"	200580-6	50,000	67,791	418	189
21.1/2" - 23"	200580-7	50,000	67,791	430	195
24" - 25.1/2"	200580-8	50,000	67,791	459	208
25.1/2" - 27"	200600-1	50,000	67,791	490	222
27" - 27.1/2"	200600-2	50,000	67,791	499	226
28.1/2" - 30"	200600-3	50,000	67,791	531	240
30" - 31.5/8"	200600-4	50,000	67,791	542	245
31.1/2" - 33"	200600-5	50,000	67,791	572	259
33" - 34.1/2"	200600-6	50,000	67,791	612	277
34.1/2" - 36"	200600-7	50,000	67,791	618	280

## CASING TONG HEAD SIZE COMPONENTS\*

		Fig. A	Fig. B	Fig.C	Fig. D	Fig.E	Fig F	Fig G	Fig.H	
Part no.:		200580-1	200580-2	200580-3	200580-4	200580-5	200580-6	200580-7	200580-8	
Ref.	Description	No. req.	No. req.	No. req.	No. req.	No. req.	No. req.	No. req.	No. req.	Part. No
7	Hinge jaw ass'y A		1		1	2	1	2	2	200584-1
8	Hinge jaw ass'y B	1	1	1	1	1	1	1	1	200585-1
9	Hinge jaw ass'y C	1	-	2	1	-	2	1	2	200586-1
		Fig I.	Fig J	Fig. K	Fig. L	Fig. M	Fig. N	Fig.O		
Part no.:		200600-1	200600-2	200600-3	200600-4	200600-5	200600-6	200600-7		
Ref.	Description	No. req.	No. req.	No. req.	No. req.	No. req.	No. req.	No. req.	No. req.	Part no.
7	Hinge jaw ass'y D	3	4	3	4	3	2	2		200604-1
8	Hinge jaw ass'y E	1	1	3	2	2	2	5		200605-1
9	Hinge jaw ass'y F	1	-	-	-	2	4	1		200606-1

\* Note: It is possible to combine the number of jaws. One doesn't need to purchase a casing head tong for each size.

Example 1: When purchasing pn 200600-4 (30" - 31.1/2") comprising 4 x pn 200604-1 and 2 x pn 200605-1, one can assemble pn 200600-5 (31.1/2" - 33") comprising 3 x pn 200604-1 and 2 x pn 200605-1, however, one needs in this case also 2 x hinge jaw pn 200606-1.

Example 2: When purchasing pn 200580-8 (24" - 25.1/2") comprising 2 x pn 200584-1, 1 x pn 200585-1 and 2 x pn 200586-1, one can assemble pn 200580-7 (21.1/2" - 23") by leaving out 1 x pn 200586-1.

## PARTS LIST HT 50 CASING HEAD ASSEMBLIES

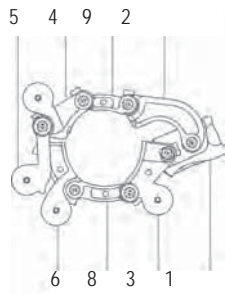

Fig A, 13.3/8"-14<sup>1</sup>/<sub>2</sub>", Part no. 200580-1

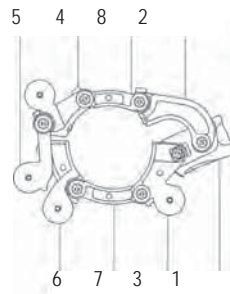

Fig B, 14.1/2"-16", Part no. 200580-2

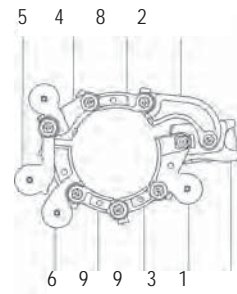

Fig C, 16"-17.1/2", Part no. 200580-3

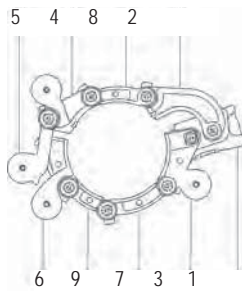

Fig D, 17.1/2"-19", Part no. 200580-4

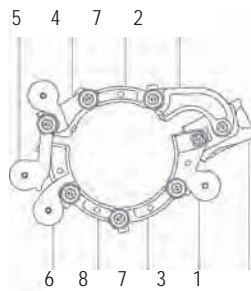

Fig E, 19"-20", Part no. 200580-5

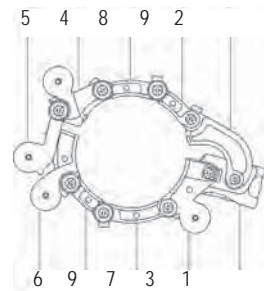

Fig F, 20"-21.1/2", Part no. 200580-6

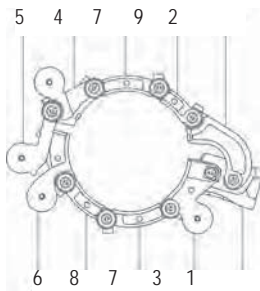

Fig G, 21.1/2"-23", Part no. 200580-7

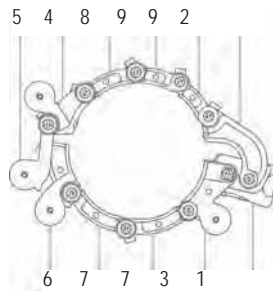

Fig H, 24"-25.1/2", Part no. 200580-8

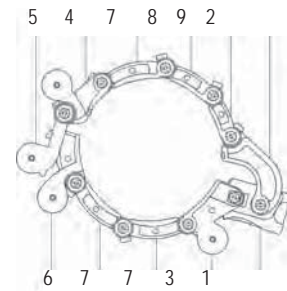

Fig I, 25.1/2"-27", Part no. 200600-1

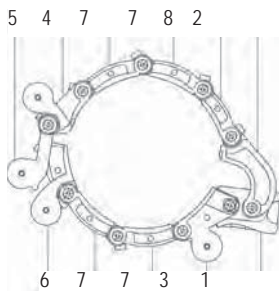

Fig J, 27"-28.1/2", Part no. 200600-2

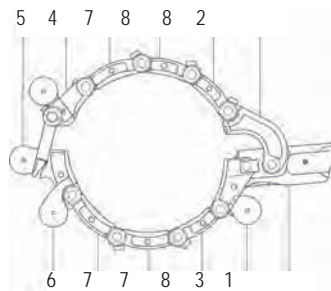

Fig K, 28.1/2"-30", Part no. 200600-3

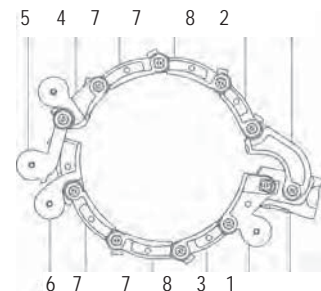

Fig L, 30"-31.1/2", Part no. 200600-4

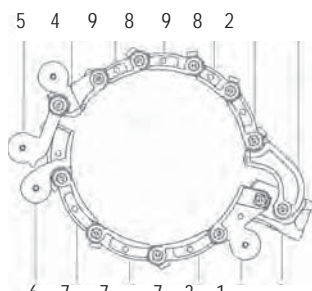

Fig M, 31.1/2"-33", Part no. 200600-5

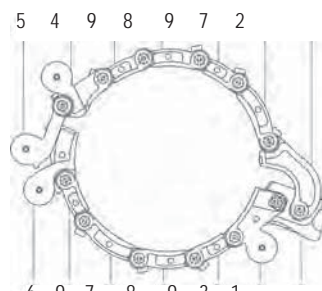

Fig N, 33"-34.1/2", Part no. 200600-6

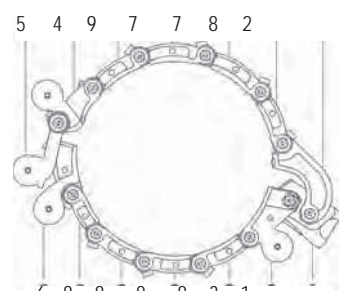

Fig O, 34.1/2"-36", Part no. 200600-7



# CASING RUNNING TOOLS

## CRT350 & CRT500 CASING RUNNING TOOL

The CRT introduces step change in the way casing is run today. By combining the functionality of field proven tools such as the top drive, flush mounted slip (FMS), fill and circulation tool and hydraulic single joint elevator (H-SJH & UX), casing operations are now safer, faster and more efficient. The CRT, which is connected directly to the top drive main shaft, hoists and lowers casing, spins in and makes up the casing connection. Additionally, while reciprocating and rotating the casing string, the CRT has the ability to fill-up and circulate.

### Safety

- Eliminates stabbing-board operations (leading contributor to LTA's while running casing), less manual handling in the V-door and fewer safety hazards.
- Power casing tong operations and work platforms have been removed, allowing for better ergonomics and work space around the well center.

### Economics

- Drilling contractors or a reduced casing crew can run the casing, minimizing stand-by costs associated with weather or problematic well conditions.
- The CRT integral compensator substantially reduces the risk of damage due to cross-threading.
- Utilizing the top drive to control make-up reduces thread damage during the complete make-up cycle.

### Well Improvements

- Assures that the casing can be set to the casing point with the ability of the CRT to push casing to bottom, fill, circulate, rotate, and reciprocate.
- Reduces the risk of differential wall sticking.
- Ability to pressure test.

### Efficiency

- Less equipment to rig up; the CRT contains the single joint elevator, rigid link hoist and stabbing assembly, fill and circulation tool, and compensator in one assembly.
- Single load-path design eliminates links.
- The operator determines and controls the running/tripping speed, spin-in and make-up torques.
- When running mixed strings, size of components can be changed within minutes through the twist lock design.

### Features CRT Compensator

- Employs a patented cushioned weight compensator which balances out the weight of CRT.
- Soft stabbing and thread compensation minimizes casing thread damage.

### CRT Pipe Sensor

- The pipe sensor detects the casing coupling so slips will set automatically at the correct position, ensuring casing connection integrity.
- Provides feedback to CRT operator that the correct CRT stabbing height is reached.

### CRT Fill-up and Circulation Tool

- Fill-up tool enables fast change out of seal and guide elements when mixed strings are run.
- Prevents possible spills of expensive fluids.
- Reduces the risk of environmental incidents.

### Single Joint Elevators

- Hydraulic operated SJ-elevator (H-SJH & UX)
- Hydraulic cylinder assembly to tilt the H-SJH elevator to the V-door.



CRT350 with H-SJH elevator



CRT500 with H-SJH elevator

## TECHNICAL SPECIFICATIONS CRT350

Description	Value
API 8C Load Rating [sTon/Tonne]	350 / 317
Casing Size	4.1/2" to 9.7/8"
Fill-Up and Circulation	4.1/2" to 9.7/8" circulation and fill-up (fill-up, circulate, and recovery over the full range)
Maximum Mud Circulation Pressure [psi/kPa]	up to 5,000 / 34,474 (size dep.)
Rotational speed [rpm]	0-20 intermittent
Weight (fully dressed, typical) [lbs/kg]	10,500 / 4,785
Maximum Push Down Force [lbs/kg]	20,000 / 9,072 (static)
Temperature Range [°C/°F]	-20° to +55° / -4° to 131°
Maximum Torque [ft.lbs / Nm]	35,000 / 47,453
Shaft connection	6.5/8" API RH (box), 7.750" OD TJ.
Diameter of CRT body	32"
Width of CRT ass'y	44.3"
Height*	117" (compensator mid stroke, from shaft shoulder + CRT bell guide)
Height	139.8" (link arm fully in, from shaft shoulder to H-SJH)

## MAIN PART NUMBERS

Part number	Description
50008500Y*	CRT350 Casing Running Tool
50008610	Independent Control Panel
50008551	Portable service loop

## TECHNICAL SPECIFICATIONS CRT500

Description	CRT500-14
API 8C Load Rating [sTon/Tonne]	500 / 454
Casing Size	4.1/2" to 14"
Fill-Up and Circulation	4.1/2" -14" Circulation / Fill-up & recovery over the full range.
Maximum Mud Circulation Pressure [psi/kPa]	up to 5,000 / 34,474, size dependant
Rotational speed [rpm]	0-20
Weight (fully dressed) [lbs/kg]	17,636 / 8,000
Maximum Push Down Force [lbs/kg]	40,000 / 18,100
Temperature Range [°C/°F]	-20° to +55° / -4° to 131°
Maximum Torque [ft.lbs@psi / Nm @ kPa]	55,000 @ 2,500 / 74,570 @ 17,236)
Shaft connection	7.5/8" API RH (box), 8.625"OD TJ.
Diameter of CRT body	40"
Width of CRT ass'y	53.5"
Height*	146.4"
Height	166.8" (link arm fully in)

\* Stackup length is from TDS Bell Guide to top of main shaft (w/o X-over sub)

## MAIN PART NUMBERS

Part number	Part
50002500Y*	CRT500-14
50008610	Independent Control Panel
50008551	Portable service loop

\* Contact NOV for details.

\*\* For the use of the 16" - 20" body, a CRT500-14 pn 50002500Y is needed.

## SIZE COMPONENTS CRT350: SLIPS AND INSERTS

Casing : 4.1/2" up to 9.7/8"				
Size	Insert	Part Number	Qty (per slip ass'y)	Part Number, Slip Ass'y
4.1/2"		2165	8	50008566Y412
Slip #3 à 5.1/2" Nominal, CASING				
4.1/2"		2168	12	50008567Y412
5"		2169	12	50008567Y500
5.1/2"		2170	12	50008567Y512
Slip #4 à 7.5/8" Nominal, CASING				
6.5/8"		2632	16	50008568Y658
7"		2623	16	50008568Y700
7.5/8"		2633	16	50008568Y758
7.3/4"		2649	16	50008568Y734
Slip #5 à 9.5/8" Nominal, CASING				
8.5/8"		2640	20	50008569Y858
8.3/4"		2650	20	50008569Y834
9.5/8"		2633	20	50008569Y958
9.3/4"		2649	20	50008569Y934
9.7/8"		2649	20	50008569Y978

## SIZE COMPONENTS CRT500: SLIPS AND INSERTS

Casing : 4.1/2" up to 14"				
Slip #4.1/2" à 5.1/2" Nominal, CASING				
Size	Insert	Part Number	Qty (per slip ass'y)	Part Number, Slip Ass'y
4.1/2"		2168	18	50002567Y412
5"		2169	18	50002567Y500
5.1/2"		2170	18	50002567Y512
Slip #6.5/8" à 7.3/4" Nominal, CASING				
6.5/8"		2632	24	50002568Y658
7"		2623	24	50002568Y700
7.5/8"		2633	24	50002568Y758
7.3/4"		2649	24	50002568Y734
Slip #8.5/8" à 9.7/8" Nominal, CASING				
8.5/8"		2640	30	50002569Y858
8.3/4"		2650	30	50002569Y834
9.5/8"		2633	30	50002569Y958
9.3/4"		2649	30	50002569Y934
9.7/8"		2649	30	50002569Y978
Slip #10.3/4" à 12" Nominal, CASING				
10.3/4"		2640	42	50002570Y1034
10.7/8"		2650	42	50002570Y1078
11.3/4"		2637	42	50002570Y1134
11.7/8"-12"		2651	42	50002570Y1178
Slip #12.3/4" à 14" Nominal, CASING				
12.3/4"		2657	42	50002571Y1234
13.3/8"		2636	42	50002571Y1338
13.1/2"		2652	42	50002571Y1312
13.5/8"		2653	42	50002571Y1358
14"		2635	42	50002571Y1400

## SIZE COMPONENTS: CRT350: BOTTOM GUIDES

Part number for CRT350	Bottom guide (nominal pipe size)	Inner Diameter
50008588	4.1/2"	5.750"
50008589	5"	6.250"
50008590	5.1/2"	6.750"
50008591	6.5/8"	8.250"
50008592	7"	8.250"
50008593	7.5/8"	9.250"
50008594	8.5/8"	10.250"
50008595	9.5/8"	11.250"
50008596	9.3/4" & 9.7/8"	11.500"

## SIZE COMPONENTS CRT500: BOTTOM GUIDES

Part number for CRT500-14	Bottom guide (nominal pipe size)	Inner Diameter
50002583	4.1/2"	5.75"
50002584	5"	6.25"
50002585	5.1/2"	6.72"
50002586	6.5/8" & 7"	8.25"
50002587	7.1/2" upto 7.7/8"	9.25"
50002588	8.5/8" & 8.3/4"	10.25"
50002589	9.5/8"	11.25"
50002590	9.3/4" & 9.7/8"	11.50"
50002591	10.3/4" & 10.7/8"	12.38"
50002592	11.3/4" upto 12"	13.31"
50002593	12.3/4" & 12.7/8"	14.50"
50002594	13.3/8"	15.00"
50002595	13.1/2" upto 13.3/4"	15.25"
50002596	14"	15.62"



MAIN PART NUMBERS FAC TOOL

CRT	Part number	Range
CRT350	59000361*	4.1/2" - 6.5/8"
CRT350	59000360*	7" - 9.7/8"
CRT500	59000360*	7" - 14"

\* Depends on size components



SIZE COMPONENTS: FAC TOOLS

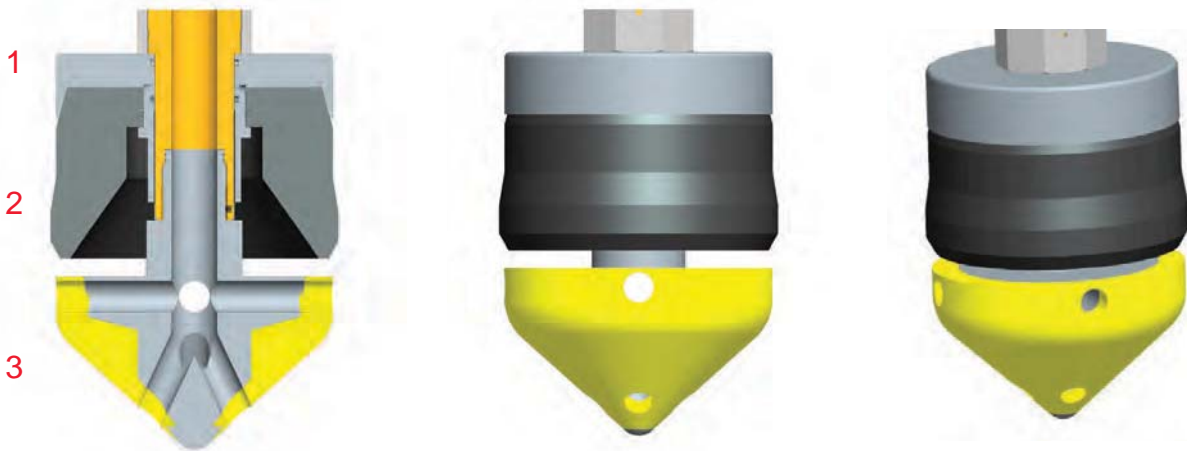

- 1: Thimble
- 2: Packer Cup
- 3: Noze cone

## SIZE COMPONENTS FAC TOOL 4.1/2" - 5"

Pipe size	Pipe weight (range)	Casing I.D.	Thimble item 1	Packer Cup item 2 partnumber	Cup OD.	Nose cone item 3 partnumber	Nose cone OD.	Remarks
4.1/2"	9.5 -11.6 #	4.090" -4.000"	59000377-412-9	59000378-412-9	4.15"	59000379-412-9	3.875"	
4.1/2"	12.6 -13.5#	3.958" -3.920"	59000377-412-9	59000378-412-13	4.08"	59000379-412-13	3.795"	
4.1/2"	15.1#	3.826"	59000377-412-15	59000378-412-15	3.95"	59000379-412-15	3.710 "	Smallest possible drift
5.00"	15 -18#	4.408" -4.276"	59000377-500-15	59000378-500-15	4.62"	59000379-500-15	4.151"	
5.00"	18 - 21#	4.276" -4.126"	59000377-500-18	59000378-500-18	4.34"	59000379-500-15 59000379-500-21	4.151" 3.919"	5.00" 20.3# Upwards Cone 59000379-500-21

Available size components for 4.1/2" casing			Available size components for 5" casing		
Parts marked with a Qty are part of size component kit 59000362-412			Parts marked with a Qty are part of size component kit 59000362-500		
Qty	NOV Part number	Description	Qty	NOV Part number	Description
1	59000377-412-9	Thimble 4.1/2" 9.5/11 6# 12.6/13.5#	1	59000377-500-15	Thimble 5.00" 15/18# 18/21#
1	59000377-412-15	Thimble 4.1/2" 15.1#	1	59000378-500-15	Cup 5.00" 15/18#
1	59000378-412-9	Cup 4.1/2" 9.5/11.6#	1	59000378-500-18	Cup 5.00" 18/21#
1	59000378-412-13	Cup 4.1/2" 12.6/13.5#	1	59000379-500-15	Nose cone 5.00" 15/18#
1	59000378-412-15	Cup 4.1/2" 15.1#	1	59000379-500-21	Nose cone 5.00" 21/23#
1	59000379-412-9	Nose cone 4.1/2" 9.5/11.6#			
1	59000379-412-13	Nose cone 4.1/2" 12.6/13.5#			
1	59000379-412-15	Nose cone 4.1/2" 15.1#			

## SIZE COMPONENTS FAC TOOL 5.1/2" - 6.5/8"

Pipe size	Pipe weight (range)	Casing I.D.	Thimble item 1	Packer Cup item 2 partnumber	Cup OD.	Nose cone item 3 partnumber	Nose cone OD.	Remarks
5.1/2"	14 -17 #	5.012" -4.892"	59000377-512-17	59000378-512-17	5.20"	59000379-512-14	4.767"	
5.1/2"	17 -23 #	4.892" -4.670"	59000377-512-17	59000378-512-17	4.98"	59000379-512-14 59000379-512-20	4.767" 4.545"	5.1/2" 20# use cone 59000379-550-20
6.5/8"	24 -28 #	5.920"-5. 791"	59000377-658-24	59000378-658-24	6.01"	59000379-658-24	5.67"	
6.5/8"	32 #	5.675"	59000377-658-24	59000378-658-32	5.83"	59000379-658-32	5.55"	

Available size components for 5.1/2" casing			Available size components for 6.5/8" casing		
Parts marked with a Qty are part of size component kit 59000362-512			Parts marked with a Qty are part of size component kit 59000362-658		
Qty	NOV Part number	Description	Qty	NOV Part number	Description
1	59000377-512-14	Thimble 5.1/2" 14/17-17/23#	1	59000377-658-24	Thimble 6.5/8" 24/28# 32#
1	59000378-512-14	Cup 5.112" 14/17#	1	59000378-658-24	Cup 6.5/8" 24/28#
1	59000378-512-17	Cup 5.112" 17/23#	1	59000378-658-32	Cup 6.5/8" 32#
1	59000379-512-14	Nose cone 5.1/2" 14/17#	1	59000379-658-24	Nose cone 6.5/8" 24/28#
1	59000379-512-20	Nose cone 5.1/2" 20/23#	1	59000379-658-32	Nose cone 6.5/8" 32#

## SIZE COMPONENTS FAC TOOL 7" - 7.5/8"

Pipe size	Pipe weight (range)	Casing I.D.	Thimble item 1	Packer Cup item 2 partnumber	Cup OD.	Nose cone item 3 partnumber	Nose cone OD.	Remarks
7.00"	17 -23 # (Premium)	6.538" -6.366"	59000377-700-17	59000378-700-17(PR)	6.62"	59000379-700-17	6.25"	
7.00"	26 -30 # (Premium)	6.276" -6.154"	59000377-700-17	59000378-700-26(PR)	6.38"	59000379-700-26	6.00"	
7.00"	32 # (Premium)	6.094"	59000377-700-22	59000378-700-32(PR)	6.20"	59000379-700-26	6.00"	Smallest drift dia. F AC #59000360: 5.695"
7.5/8"	24 -26.4 # (Premium)	7.025" -6.969"	59000377-758-24	59000378-758-24(PR)	7.25"	59000379-758-24	6.75"	
7.5/8"	29.7 -33.7 # (Premium)	6.875" -6.765"	59000377-758-24	59000378-758-30(PR)	6.92"	59000379-758-24 59000379-758-34	6.75" 6.50"	7.5/8" 33.7# use 59000378-758-34
7.5/8"	39 # (Premium)	6.625"	59000377-758-24	59000378-758-39(PR)	6.72"	59000379-758-34	6.50"	

Available size components for 7" Butress casing			Available size components for 7" Premium casing		
Parts marked with a Qty are part of size component kit 59000362-700			Parts marked with a Qty are part of size component kit 59000362-700PR		
Qty	NOV Part number	Description	Qty	NOV Part number	Description
1	59000377-700-17	Thimble 7.00" 17120#, 17123#, 26/30#	1	59000377-700-17	Thimble 7.00" 17120#, 17123#, 26/30#
1	59000377-700-22	Thimble 7.00" 22/24#, 12/26#, 32#	1	59000377-700-22	Thimble 7.00" 22/24#, 12/26#, 32#
1	59000378-700-17	Cup 7.00" 17/23#	1	59000378-700-17PR	Cup 7.00" 17/23# Premium
1	59000378-700-26	Cup 7.00" 26/30#	1	59000378-700-26PR	Cup 7.00" 26/30# Premium
1	59000378-700-32	Cup 7.00" 32#	1	59000378-700-32PR	Cup 7.00" 32# Premium
1	59000379-700-17	Nose cone 7.00" 17/23#	1	59000379-700-17	Nose cone 7.00" 17/23#
1	59000379-700-26	Nose cone 7.00" 26/32#	1	59000379-700-26	Nose cone 7.00" 26/32#

Available size components for 7.5/8" Butress casing			Available size components for 7.5/8" Premium casing		
Parts marked with a Qty are part of size component kit 59000362-758			Parts marked with a Qty are part of size component kit 59000362-758PR		
Qty	NOV Part number	Description	Qty	NOV Part number	Description
1	59000377-758-24	Thimble 7.5/8" (all weight ranges)	1	59000377-758-24	Thimble 7.5/8" (all weight ranges)
1	59000378-758-24	Cup 7.5/8" 24/26.4# Premium	1	59000378-758-24PR	Cup 7.5/8" 24/26.4# Premium
1	59000378-758-30	Cup 7.5/8" 29.7/33.7# Premium	1	59000378-758-30PR	Cup 7.5/8" 29.7/33.7# Premium
1	59000378-758-39	Cup 7.5/8" 39# Premium.	1	59000378-758-39P	Cup 7.5/8" 39# Premium
1	59000379-758-24	Nose cone 7.5/8" 24/29.7#	1	59000379-758-24	Nose cone 7.5/8" 24/29.7#
1	59000379-758-34	Nose cone 7.5/8" 33.7/39#	1	59000379-758-34	Nose cone 7.5/8" 33.7/39#

## SIZE COMPONENTS FAC TOOL 8.5/8" - 9.5/8"

Pipe size	Pipe weight (range)	Casing I.D.	Thimble item 1	Packer Cup item 2 partnumber	Cup OD.	Nose cone item 3 partnumber	Nose cone OD.	Remarks
8.5/8"	20 -24 #	8.191 "-8.097"	59000377 -858-20	59000378-858-20	8.26"	59000379-858-20	8.00"	
8.5/8"	28 -36 #	8.017 "-7.825"	59000377 -858-28	59000378-858-28	8.15"	59000379-858-28	7.70"	
9.5/8"	36 -43 # (Premium)	8.921 "-8.755"	59000377-958-36	59000378-958-36(PR)	9.05"	59000379-958-36	8.625"	
9.5/8"	40 -47 # (Premium)	8.835" -8.681"	59000377-958-40	59000378-958-40(PR)	8.85"	59000379-958-36 59000379-958-47	8.625" 8.375"	9.5/8" 47# use 59000379-958-47
9.5/8"	47 -53 # (Premium)	8.681" -8.535"	59000377-958-40	59000378-958-47(PR)	8.75"	59000379-958-47	8.375"	
9.5/8"	53 -58 # (Premium).	8.535" -8.435"	59000377-958-53	59000378-958-53PR	8.65"	59000379-958-53	8.220"	

Available size components for 8.5/8" Butress casing			Available size components for 9.5/8" Butress casing		
Parts marked with a Qty are part of size component kit 59000362-858			Parts marked with a Qty are part of size component kit 59000362-958		
Qty	NOV Part number	Description	Qty	NOV Part number	Description
1	59000377-858-20	Thimble 8.5/8" 20/24#	1	59000377-958-36	Thimble 9.5/8" 36/43#
1	59000377-858-28	Thimble 8.5/8" 28/36#	1	59000377-958-40	Thimble 9.5/8" 40/47- 47/53#
1	59000378-858-20	Cup 8.5/8" 20/24#	1	59000378-958-36	Cup 9.5/8" 36/43#
1	59000378-858-28	Cup 8.5/8" 28/36#	1	59000378-958-40	Cup 9.5/8" 40/47#
1	59000379-858-20	Nose cone 8.5/8" 20/24#	1	59000378-958-47	Cup 9.5/8" 47/53.5#
1	59000379-858-28	Nose cone 8.5/8" 28/36#	1	59000379-958-36	Nose cone 9.5/8" 36/43#
			1	59000379-958-47	Nose cone 9.5/8" 47/53#

Available size components for 9.5/8" Premium casing		
Parts marked with a Qty are part of size component kit 59000362-958PR		
Qty	NOV Part number	Description
-	59000377-958-36	Thimble 9.5/8" 36/43#
1	59000377-958-40	Thimble 9.5/8" 40/47-47/53#
1	59000377-958-53	Thimble 9.5/8" 53/58#
-	59000378-958-36PR	Cup 9.5/8" 36/43# Premium.
1	59000378-958-40PR	Cup 9.5/8" 40/47# Premium.
1	59000378-958-47PR	Cup 9.5/8" 47/53# Premium.
1	59000378-958-53PR	Cup 9.5/8" 53/58# Premium.
1	59000379-958-36	Nose cone 9.5/8" 36/43#
1	59000379-958-47	Nose cone 9.5/8" 47/53#
1	59000379-958-53	Nose cone 9.5/8" 53/58#

SIZE COMPONENTS FAC TOOL 10.3/4"

Pipe size	Pipe weight ( range )	Casing I.D.	Thimble item 1	Packer Cup item 2 partnumber	Cup OD.	Nose cone item 3 partnumber	Nose cone OD.	Remarks
10.3/4"	32-55 #	10.192" -9.760"	59000377-1034-32	59000378-1034-32	10.20"	59000379-1034-32	9.794"	10.3/4" 32-46#
10.3/4"	60-73 #	9.660" -9.406"	59000377-1034-60	59000378-1034-60	9.72"	59000379-1034-55 59000379-1034-65 59000379-1034-73	9.604" 9.404" 9.250"	10.3/4" 51-55# 10.3/4" 60-65# 10.3/4" 71-73#
10.3/4"	51-55 # Premium	9.850" -9.760"	59000377-1034-32	59000378-1034-51PR	10.10"	59000379-1034-51 59000379-1034-55	9.694" 9.604"	10.3/4" 51# 10.3/4" 55#
10.3/4"	60-65 # Premium	9.660" -9.560"	59000377-1034-60	59000378-1034-60PR	9.94"	59000379-1034-60 59000379-1034-65	9.504" 9.404"	10.3/4" 60# 10.3/4" 65#
10.3/4"	71-73 # Premium	9.450 " -9.406"	59000377-1034-60	59000378-1034-71PR	9.72"	59000379-1034-71 59000379-1034-73	9.294" 9.250"	10.3/4" 71# 10.3/4" 73#
10.3/4"	79-85 # Premium	9.282 " -9.156"	59000377-1034-79	59000378-1034-79PR	9.56"	59000379-1034-79 59000379-1034-85	9.125" 9.000"	10.3/4" 79# 10.3/4" 85#

Available size components for 10.3/4" Butress casing

Parts marked with a Qty are part of size component kit 59000362-1034

Qty	NOV Part number	Description
-	59000377-1034-32	Thimble 10.3/4" 32/55#
1	59000377-1034-60	Thimble 10.3/4" 60/73#
-	59000378-1034-32	Cup 10.3/4" 32/55#
1	59000378-1034-60	Cup 10.3/4" 60/73#
-	59000379-1034-32	Nose cone 10.3/4" 32/46#
-	59000379-1034-55	Nose cone 10.3/4" 51/55#
1	59000379-1034-65	Nose cone 10.3/4" 65#
1	59000379-1034-73	Nose cone 10.3/4" 73#

Available size components for 10.3/4" Premium casing

Parts marked with a Qty are part of size component kit 59000362-1034PR

Qty	NOV Part number	Description
1-	59000377-1034-32	Thimble 10.3/4" 32/55#
1	59000377-1034-60	Thimble 10.3/4" 60/73#
-	59000377-1034-79	Thimble 10.3/4" 79-85#
-	59000378-1034-51PR	Cup 10.3/4" 51/55# Premium.
1	59000378-1034-60PR	Cup 10.3/4" 60/65# Premium.
1	59000378-1034-71PR	Cup 10.3/4" 71/73# Premium.
-	59000378-1034-79PR	Cup 10.3/4" 79/85# Premium.
-	59000379-1034-51	Nose cone 10.3/4" 51#
-	59000379-1034-55	Nose cone 10.3/4" 55#
1	59000379-1034-60	Nose cone 10.3/4" 60#
1	59000379-1034-65	Nose cone 10.3/4" 65#
1	59000379-1034-71	Nose cone 10.3/4" 71#
1	59000379-1034-73	Nose cone 10.3/4" 73#
-	59000379-1034-79	Nose cone 10.3/4" 79#
-	59000379-1034-85	Nose cone 10.3/4" 85#

## SIZE COMPONENTS FAC TOOL 13.3/8"

Pipe size	Pipe weight (range)	Casing I.D.	Thimble item 1	Packer Cup item 2 partnumber	Cup OD.	Nose cone item 3 partnumber	Nose cone OD.	Remarks
13.3/8"	48 -54#	12.710" -12.615"	59000377-1338-48	59000378-1338-48	12.95"	59000379-1338-54	12.459"	
13.3/8"	54 -72 #	12.615" -12.347"	59000377-1338-48	59000378-1338-54	12.72"	59000379-1338-72	12.181"	
13.3/8"	54 -61 #	12.615" -12.515"	59000377-1338-48	59000378-1338-54PR	12.87"	59000379-1338-54	12.459"	13.3/8" 54#
13.3/8"	Premium 68-72 #	12.415" -12.347"	59000377-1338-48	59000378-1338-68PR	12.70"	59000379-1338-61	12.354"	13.3/8" 61#
13.3/8"	Premium 68-72 #					59000379-1338-68	12.248"	13.3/8" 68#
13.3/8"	Premium 77 #	12.275"	59000377-1338-48	59000378-1338-77PR	12.56"	59000379-1338-72	12.181"	13.3/8" 72#
13.3/8"	Premium 77 #					59000379-1338-77	12.119"	13.3/8" 77#

### Available size components for 13.3/8" Butress casing

Parts marked with a Qty are part of size component kit 59000362-1338

Qty	NOV Part number	Description
1	59000377-1338-48	Thimble 13.3/8" 48/77#
-	59000378-1338-48	Cup 13.3/8" 48/61 #
1	59000378-1338-54	Cup 13.3/8" 54/72*
1	59000379-1338-54	Nose cone 13.3/8" 54*
1	59000379-1338-72	Nose cone 13.3/8" 72*

### Available size components for 13.3/8" Premium casing

Parts marked with a Qty are part of size component kit 59000362-1338PR

Qty	NOV Part number	Description
1	59000377-1338-48	Thimble 13.3/8" 48/77#
-	59000378-1338-54PR	Cup 13.3/8" 54/61# Premium.
1	59000378-1338-68PR	Cup 13.3/8" 68/72# Premium.
-	59000378-1338-77PR	Cup 13.3/4" 77# Premium.
-	59000379-1338-54	Nose cone 13.3/8" 54#
-	59000379-1338-61	Nose cone 13.3/8" 61#
1	59000379-1338-68	Nose cone 13.3/8" 68#
1	59000379-1338-72	Nose cone 13.3/8" 72#
-	59000379-1338-77	Nose cone 13.3/8" 77#



# ROTARY SUPPORT TABLES



## RST ROTARY SUPPORT TABLE

- Smaller, lighter and more cost effective for top drive equipped rigs.
- Uses hydraulic motors directly geared to the rotary drive gear.
- Eliminates the transmission and the drive train.
- Standard hydraulic operated lock permits the table to be locked at any position, in both directions.
- Reduces the rotary skid size.
- Lower maintenance costs.
- Hydraulic dynamic slip ring allows operation of PS21/30 power slip without manually breaking/making hydraulic connections, except RST755 + False
- Central lubrication system allows easy greasing of all moving RST-parts.
- Maximum back-up torque on locks is 120,000 ft-lbs.; RST375 max. 80,000 ft-lbs.
- Can be ordered with solid or hinged adapter in size range from 37.1/2" to 75.1/2".
- External skid mounted hydraulic hook up kit (HUK) for easy maintenance.
- PS21/30 controls are included in the control station
- Recessed tracks optional
- PS Power Slip Autogreasing System available



### AVAILABLE TABLES

- RST375 is available with or without slip ring
- RST495 is available with or without slip ring
- RST605 is available with or without slip ring
- RST755 without slip ring
- RST495 and 605-False without drive motors / slip ring but including the hydraulic lock for positioning of the rotary bowl. Supplied with a hook up system for the RST and the PS21/30, provided with automated greasing for both the PS and the RST.
- RST605-H is the heavy duty version of the RST605 series with increased load capacity.

## TECHNICAL SPECIFICATIONS

RST-specifications*	RST375**	RST495**	RST495 False	RST605**	RST605 False	RST605 H**	RST755 w/o slip ring
Table size [inches]	37.1/2"	49.1/2"	49.1/2"	60.1/2"	60.1/2"	60.1/2"	75.1/2"
Load rating static [sTon/Tonne]	750 / 680	1,000 / 907	1,000 / 907	1,000 / 907	1,000 / 907	1,375 / 1,250	1,375 / 1,250
Torque max. [ft.lbs] / Nm (@ 3000 psi / 20,684 kPa)	30,000 / 40,674	45,000 / 61,011	n/a	45,000 / 61,011	n/a	45,000 / 61,011	45,000 / 61,011
Speed max. [rpm]	15	15	***	15	***	15	15
Max. operational speed [rpm]	5	5	20 ***	5	20 ***	5	5
Dimensions [LxWxH] (incl. top cover)	89" x 61.75" x 28"	105" x 82" x 30.5"	105" x 82" x 30.5"	114" x 95" x 30.5"	114" x 95" x 30.5"	114" x 95" x 31.3"	135" x 114" x 31.25"
Dimensions [LxWxH] (frame only)	86.82" x 58.78" x 28"	99" x 82" x 30.5"	99" x 82" x 30.5"	109" x 91" x 30.5"	109" x 91" x 30.5"	109" x 91" x 31.3"	130" x 110" x 32.25"
Weight, approx. [lbs / kg]	14,102 / 6,396	22,082 / 10,016	19,026 / 8,630	25,823 / 11,713	22,949 / 10,409	28,050 / 12,723	39,748 / 18,029
Maximum working pressure [psi / kPa]	3,000 / 20,684	3,000 / 20,684	3,000 / 20,684	3,000 / 20,684	3,000 / 20,684	3,000 / 20,684	3,000 / 20,684
Maximum flow [gpm]	75	115	10	115	10	115	115

\* All data subject to conformation by manufacturer.

\*\* Available w/ OR w/o slip ring

\*\*\* No motors.

## MAIN PART NUMBERS

The RST Rotary Support Tables are customer specific, hence the part numbers are unique for all tables. When ordering a Rotary Support Table, customer will be requested to specify dimensions, I/O etc.

Rotary Support Tables delivery will include the hook up kit, containing the required manifolds, greasing pumps and reservoirs.

## SST STATIC SUPPORT TABLE

- SST: Static table for support purposes only, has no moving parts and does not supply hydraulic fluids.
- Accommodates existing power slips with or without adapter rings.
- To be used as a auxiliary well center location.
- Table can apply back up torque via drive lug pockets.

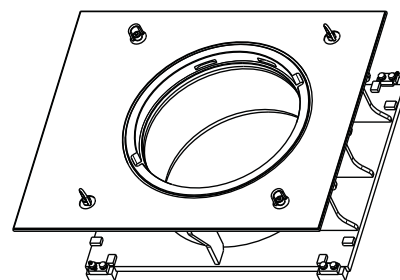

## TECHNICAL SPECIFICATIONS

SST-specifications	SST375	SST495	SST605	SST755
Table size [inches]	37.1/2"	49.1/2"	60.1/2"	75.1/2"
Load rating [sTon/Tonne]	750 / 680	1,000 / 907	1,250 / 1,134	1,375 / 1,247
Torque back-up [ft-lbs / Nm]	50,000 / 67,791	120,000 / 162,698	120,000 / 162,698	120,000 / 162,698
Dimensions [LxWxH] (incl. top cover)	89"x61.75"x28"	105"x88"x30.5"	120.13"x100.75"x35.25"	135"x114"x31.25"
Dimensions [LxWxH] (frame only)	TBD	TBD	103"x84"x35.25"	TBD
Weight, approx. [lbs/kg]	7,000 / 3,171	11,500 / 5,210	15,300 / 6,940	22,500 / 10,193

## MAIN PART NUMBERS

SST-model	SST375	SST495	SST605	SST755
Part number	50005457	50005459	50005452	50005453



# ADAPTER RINGS

## ADAPTER RINGS

Adapter rings, both solid and hinged to be used for creating a smaller hole for accommodating smaller (power) slips.



### TECHNICAL SPECIFICATIONS

Adapter-model from - to	Part number	Remark
National 75.1/2" to National 60.1/2"	50005448-1	Solid
National 75.1/2" to National 60.1/2"	50005449-1	Solid
National 75.1/2" to National 49.1/2"	50005450-1	Solid
National 60.1/2" to National 49.1/2"	50004702-1	Solid, with recess for RST hoses
National 60.1/2" to National 49.1/2"	50004703-1	Solid
National 60.1/2" to National 49.1/2"	50004704-1	Hinged, with recess for RST hoses
National 49.1/2" to National 37.1/2"	50004995	Hinged
National 49.1/2" to National 37.1/2"	50004996	Hinged, with recess for RST hoses
National 49.1/2" to Emsco 37.1/2"	250360	Hinged
Oilwell 37.1/2" to National 37.1/2"	200990-11	Hinged, 6.25" raised load shoulder
Emsco 37.1/2" to National 37.1/2"	200991-11	Hinged, 6.25" raised load shoulder
National 37.1/2" to National 37.1/2"	200995-11	Hinged, 6.25" raised load shoulder
Ideco 37.1/2" to National 37.1/2"	201430-1	Hinged, 6.25" raised load shoulder
Emsco 37.1/2" to Emsco 37.1/2"	202244-1	Hinged, 9" raised load shoulder
Emsco 37.1/2" to API -standard 27.1/2"	50004994	Hinged
National 37.1/2" to API-standard 27.1/2"	50004998	Hinged
Oilwell 37.1/2" to API-standard 27.1/2"	50004999	Hinged

### TECHNICAL SPECIFICATIONS

Size [inches]	60.1/2 to 49.1/2	60.1/2 to 49.1/2	60.1/2 to 37.1/2	49.1/2 to 37.1/2	49.1/2 to 37.1/2	37.1/2 to 27.1/2
Type	solid	split	solid	solid	split	solid
<b>National</b>						
D605	655332	M441000396				
D495				650657A	650657-2A	
C495				650657A	650657-2A	
<b>Oilwell</b>						
A 49 1/2				21111004	21111173	
B 49 1/2				21111004	21111173	
<b>CE</b>						
T-6050	0-6407-0039-00	0-6407-0039-30	0-6407-0031-00	0-6406-0038-20	6406-0038-40	
T-4950				0-6406-0038-20	6406-0038-40	
<b>Ideco</b>						
LR-495				308-189		308-102
LR-375						308-102
<b>Skytop Brewster</b>						
RSB-375						062310-33-00

**Corporate  
Headquarters**  
7909 Parkwood Circle Drive  
Houston, Texas 77036  
United States  
Phone: 713 375 3700  
Fax: 713 346 7687

*National Oilwell Varco has produced this brochure for general information only, and it is not intended for design purposes. Although every effort has been made to maintain the accuracy and reliability of its contents, National Oilwell Varco in no way assumes responsibility for liability for any loss, damage or injury resulting from the use of information and data herein. All applications for the material described are at the user's risk and are the user's responsibility.*



[www.nov.com](http://www.nov.com)

**Downhole Solutions**

**Drilling Solutions**

**Engineering and Project Management Solutions**

**Industrial Solutions**

**Lifting and Handling Solutions**

**Production Solutions**

**Supply Chain Solutions**

**Tubular and Corrosion Control Solutions**

**Well Service and Completion Solutions**

[www.nov.com](http://www.nov.com)